



LCHX Performance Curves

LCHX Index

Heat Exchanger:

Page:

8406R	1-4
8432R	5-8
8432S	9-12
10599R	13-16
10610R	17-20
10611R	21-24
10611S	25-28
10614R	29-32
10614S	33-36
10614T	37-40
10639B	41-44
10721A	45-48
10722A	49-52
10865B	53-56
10877A	57-60
10886A	61-64

8 7 6 5 4 3 2 1

		REVISIONS		
ZONE	REV	DESCRIPTION	DATE	APPROVED

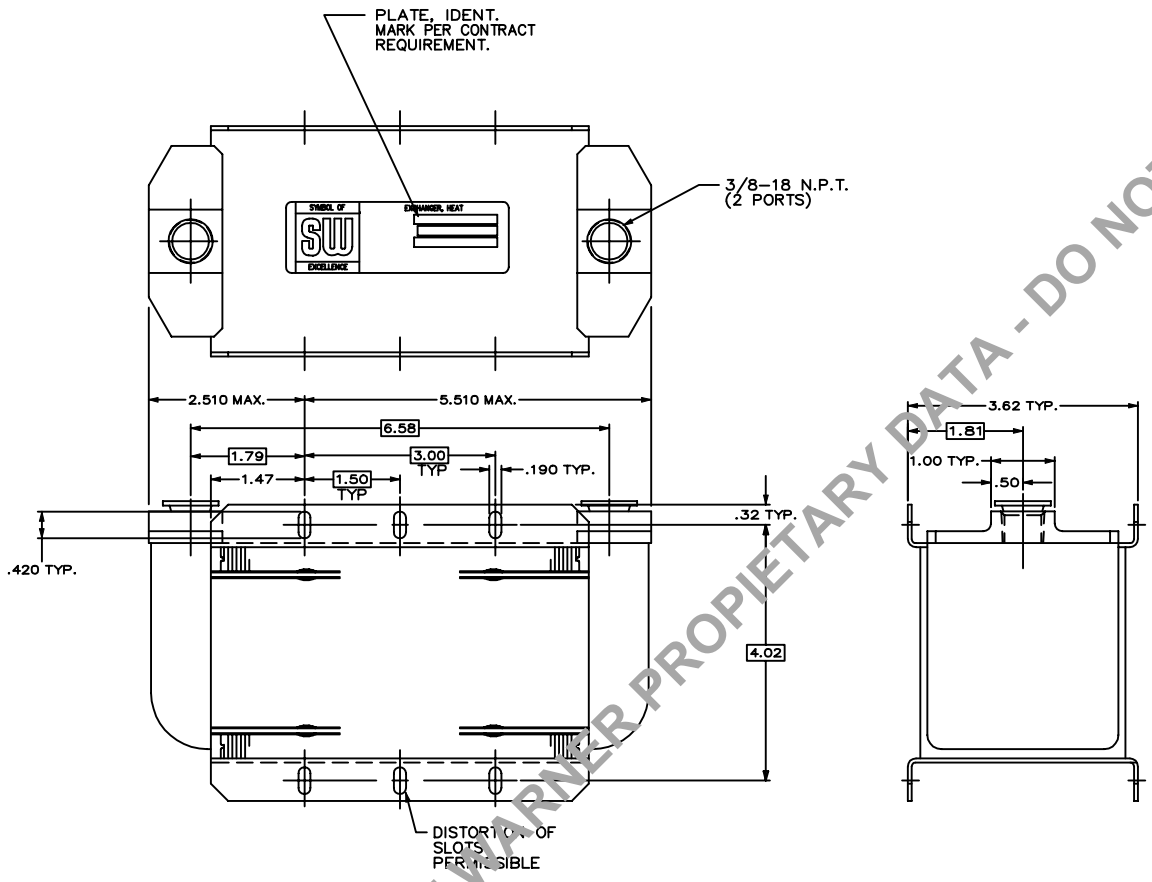

STEWART WARNER PROPRIETARY DATA - DO NOT DUPLICATE

8406R

STEWART WARNER SOUTH WIND CORPORATION INDIANAPOLIS, INDIANA		
TITLE HEAT EXCHANGER OIL COOLER		
SIZE D	CAGE NO. 78385	DWG NO. 8406R
SCALE	WT	SHEET

THIS DRAWING IS PREPARED IN ACCORDANCE WITH:
DOD-STD-360 ENGINEERING DRAWING PRACTICES AND
ANSI-Y14.5 ENGINEERING AND TOLERANCING FOR
ENGINEERING DRAWINGS.

THE INFORMATION DISCLOSED HEREIN CONTAINS PROPRIETARY
DATA OF STEWART-WARNER CORPORATION. NEITHER THIS DOCUMENT
NOR THE INFORMATION DISCLOSED HEREIN SHALL BE
REPRODUCED OR TRANSMITTED IN ANY FORM OR BY ANY
MEANS, ELECTRONIC OR MECHANICAL, INCLUDING PHOTOCOPYING,
RECORDING, OR BY ANY INFORMATION STORAGE AND RETRIEVAL
SYSTEM, WITHOUT THE WRITTEN PERMISSION OF STEWART-WARNER CORPORATION.

FORM NO. 1453 REV. 12-80 8 7 6 5 4 3 2 1

Stewart Warner 8406R Calculated Heat Rejection

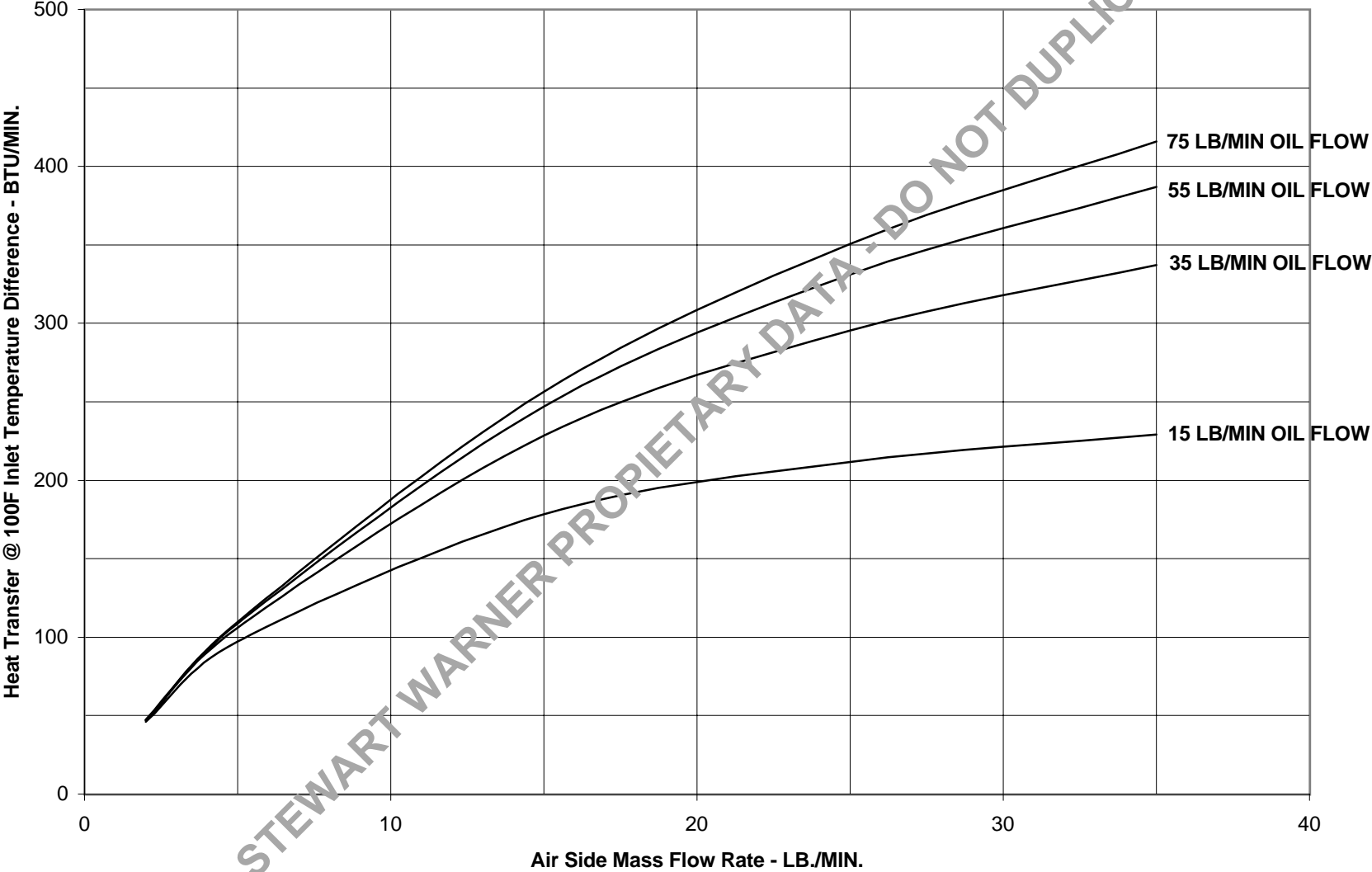

STEWART WARNER PROPRIETARY DATA - DO NOT DUPLICATE

Stewart Warner 8406R Air Side Pressure Drop

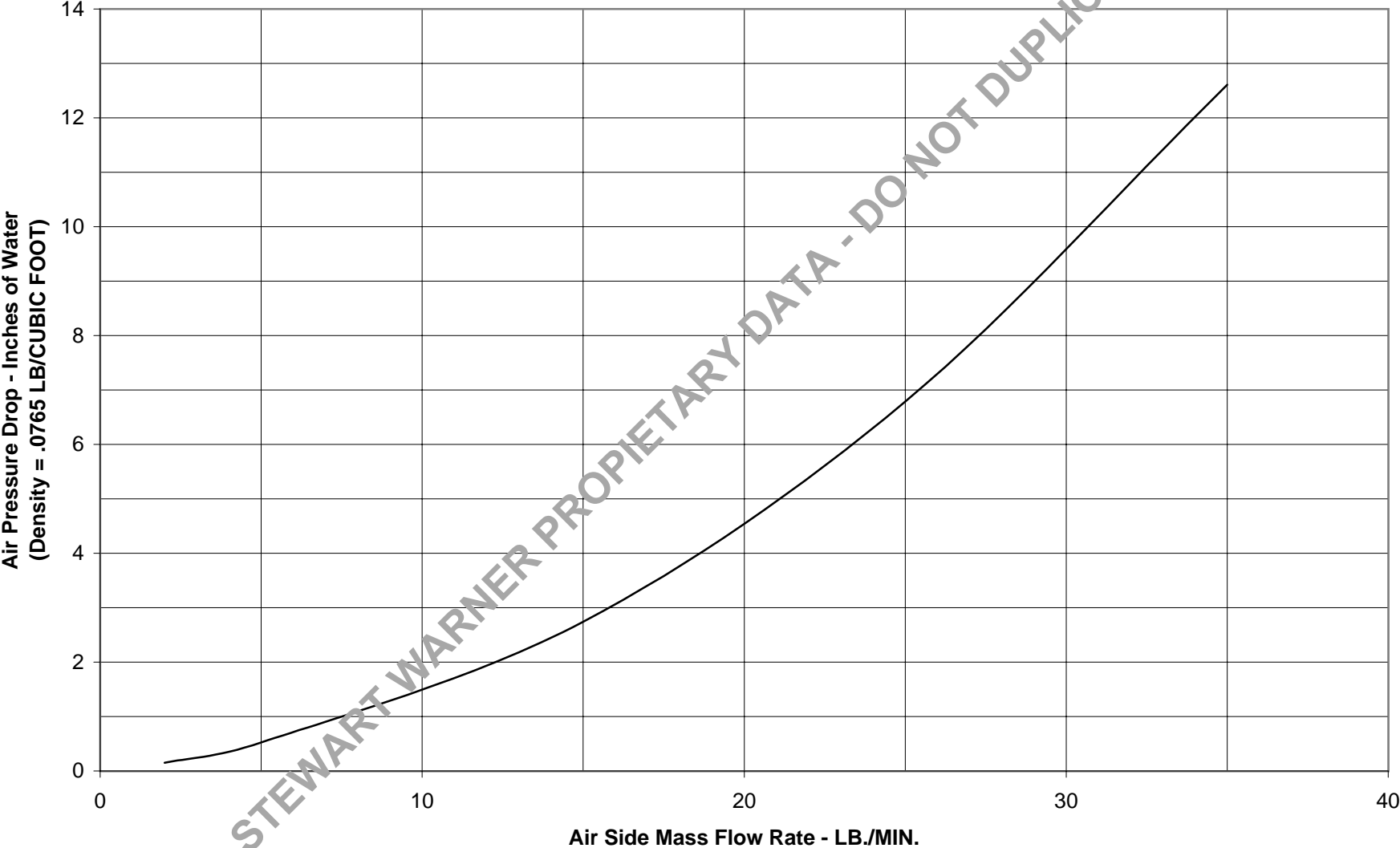

Stewart Warner 8406R Oil Side Pressure Drop

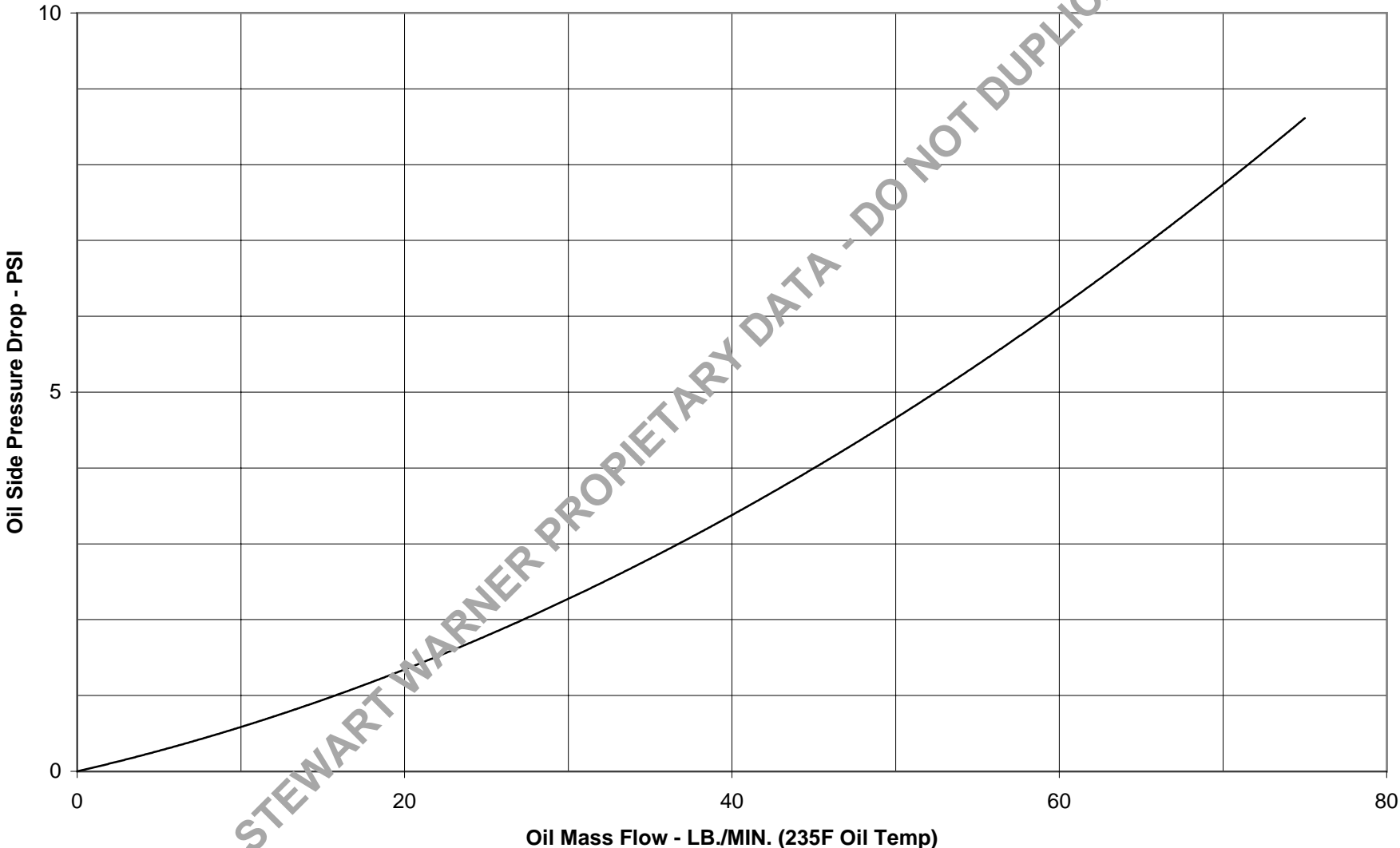

8 7 6 5 4 3 2 1

		REVISIONS			
ZONE	REV	DESCRIPTION	DATE	APPROVED	

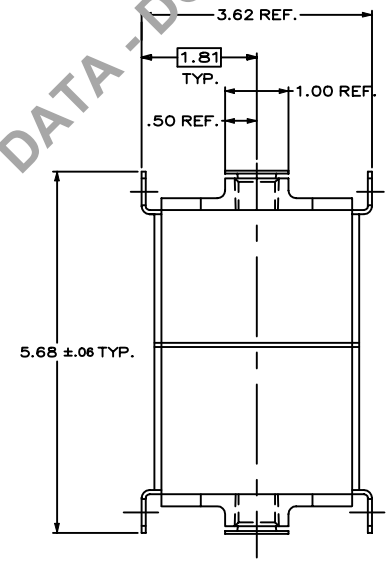
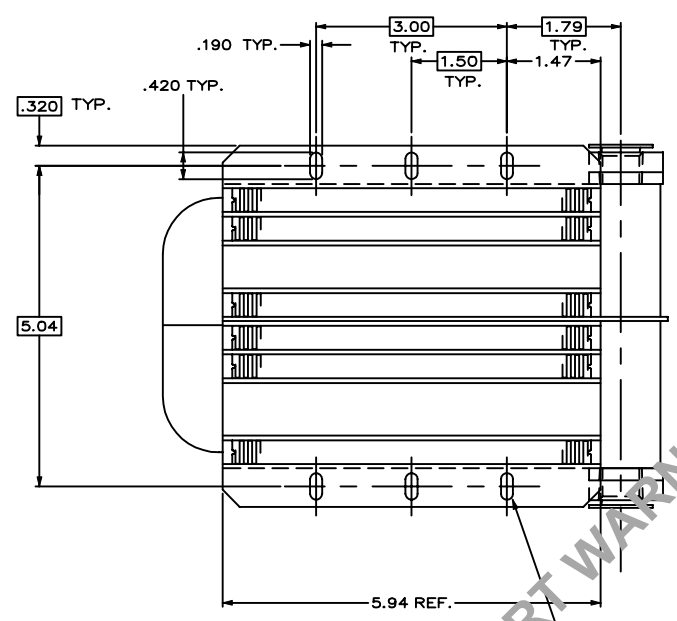
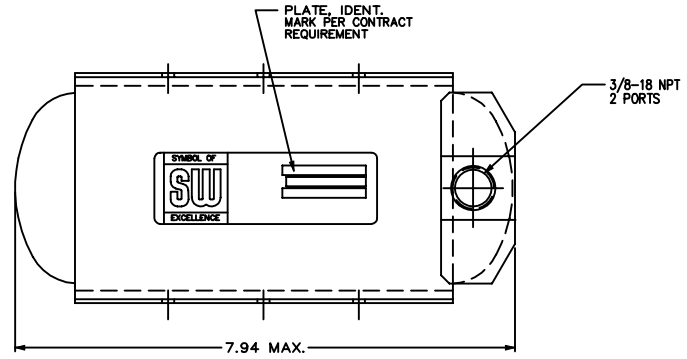

DISTORTION OF SLOTS PERMISSIBLE

STEWART WARNER PROPRIETARY DATA - DO NOT DUPLICATE

8432R

THIS DRAWING IS PREPARED IN ACCORDANCE WITH:
 ASME Y14.5-2009 ENGINEERING DRAWING PRACTICES AND
 ASME Y14.5-2003 DIMENSIONING AND TOLERANCING FOR
 ENGINEERING DRAWINGS.

THE INFORMATION DISCLOSED HEREIN CONTAINS PROPRIETARY
 DATA OF STEWART-WARNER CORPORATION. REUSE OF THIS DOC-
 UMENT WITH THE INFORMATION DISCLOSED HEREIN SHALL BE
 PROHIBITED OR TRANSFERRED TO OTHER DOCUMENTS OR USED
 FOR MANUFACTURING PURPOSES OR DISCLOSED TO OTHERS
 FOR ANY PURPOSE EXCEPT AS SPECIFICALLY AUTHORIZED IN
 WRITING BY STEWART-WARNER CORPORATION.

STEWART WARNER SOUTH WIND CORPORATION INDIANAPOLIS, INDIANA			
TITLE HEAT EXCHANGER OIL COOLER			
SIZE D	CAGE NO. 78385	DWG NO. 8432R	
SCALE	WT	SHEET	

FORM NO. 1453 REV. 12-80 8 7 6 5 4 3 2 1

Stewart Warner 8432R Calculated Heat Rejection

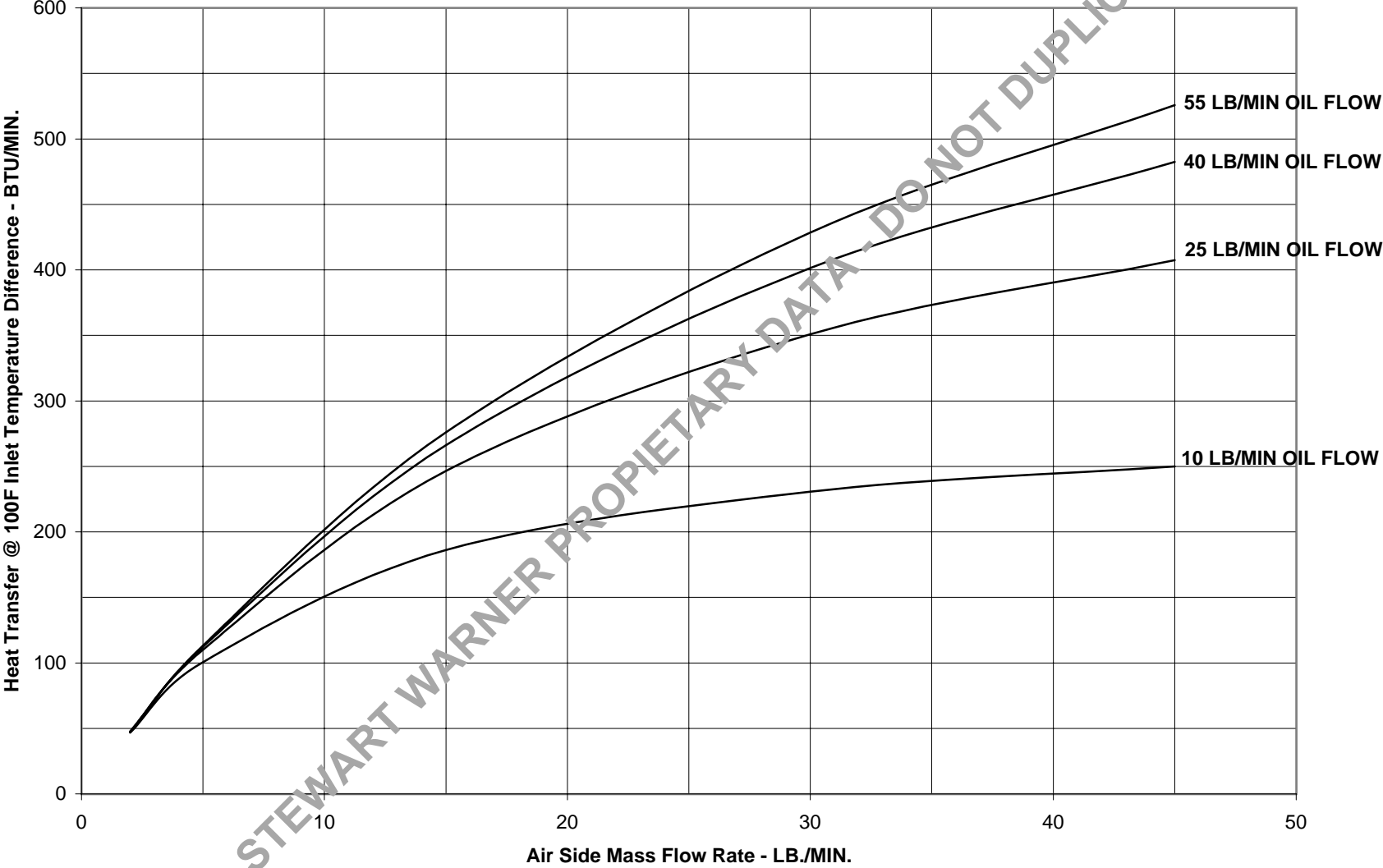

Stewart Warner 8432R Air Side Pressure Drop

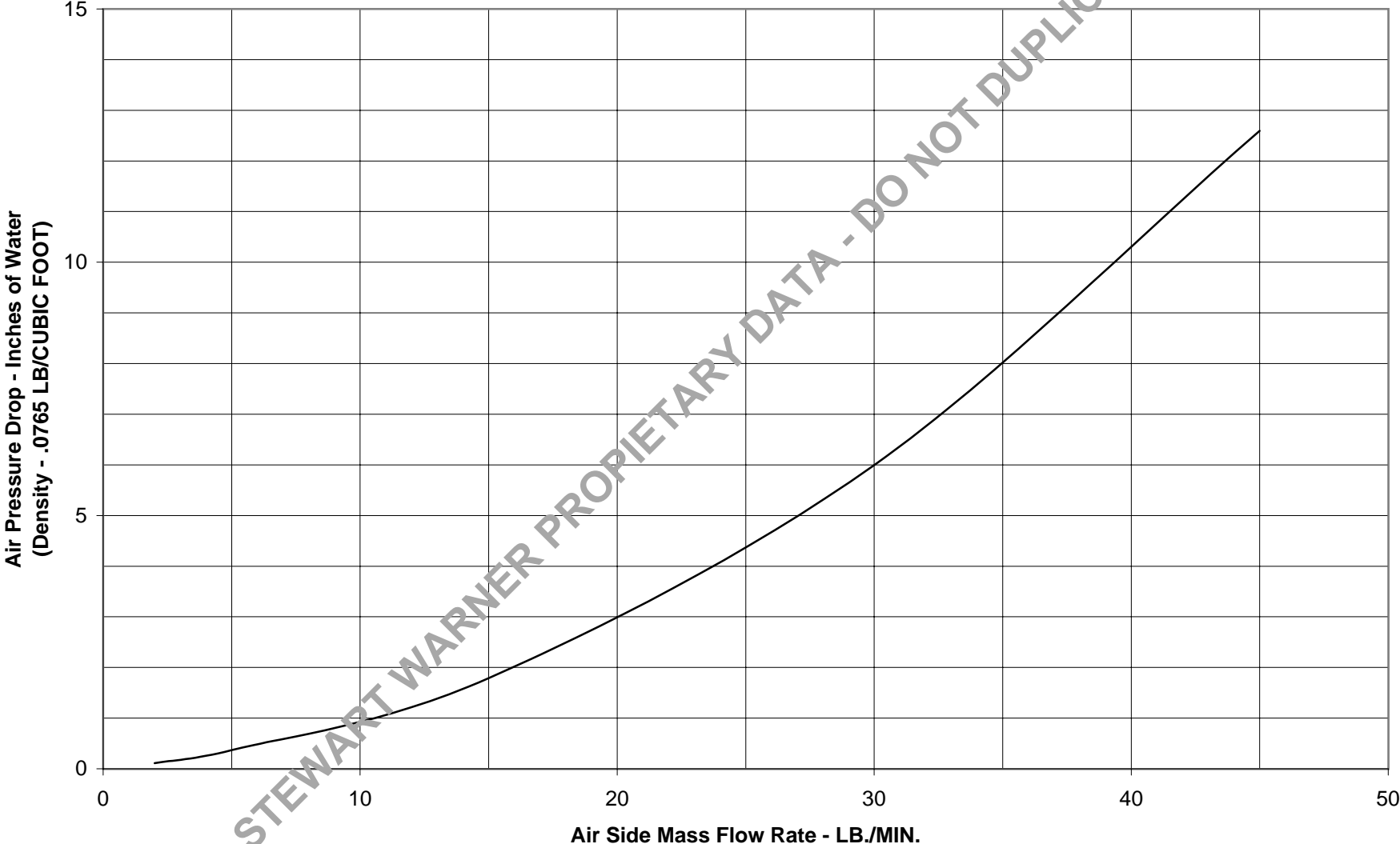

Stewart Warner 8432R Oil Side Pressure Drop

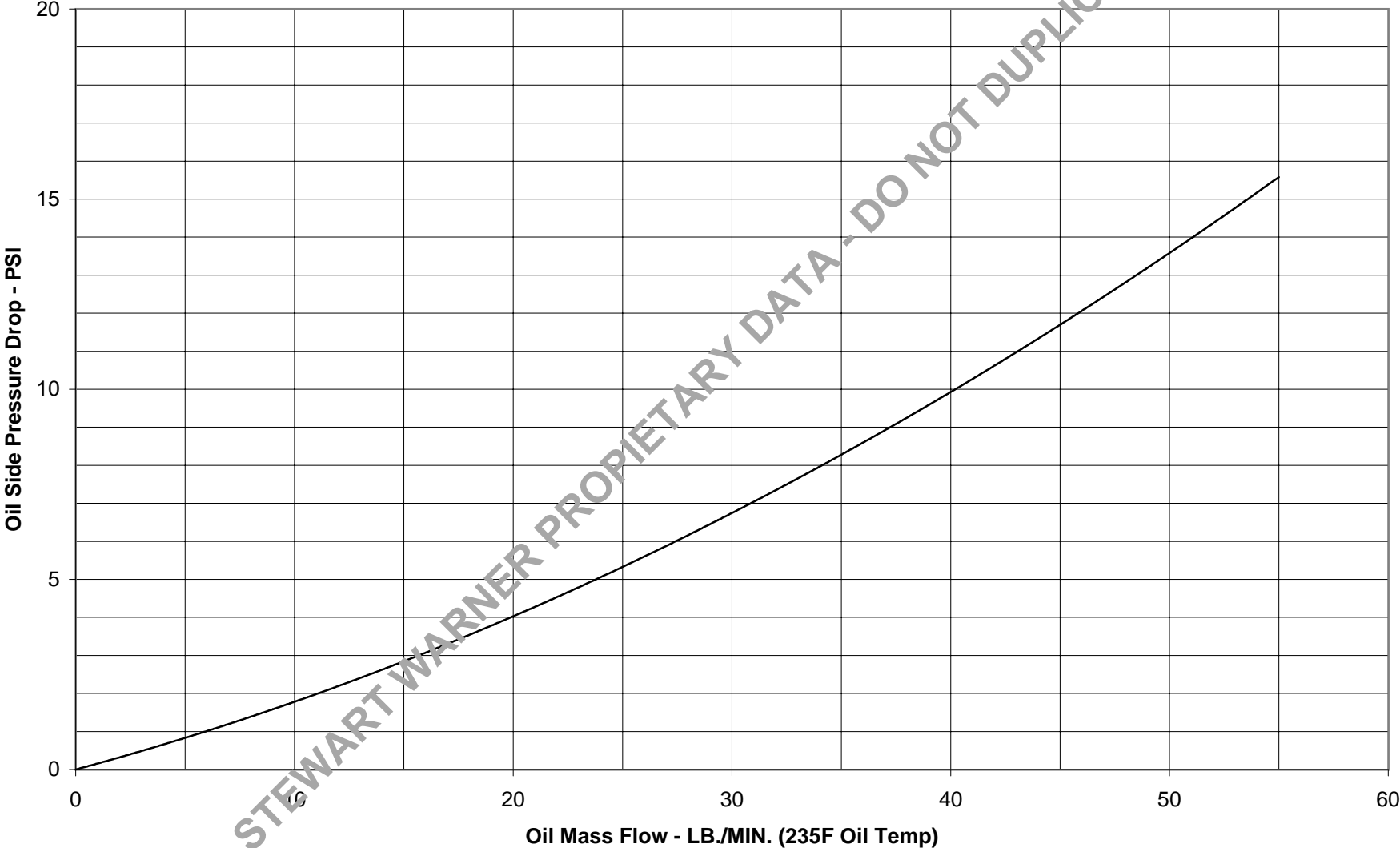

8 7 6 5 4 3 2 1

		REVISIONS			
ZONE	REV	DESCRIPTION	DATE	APPROVED	

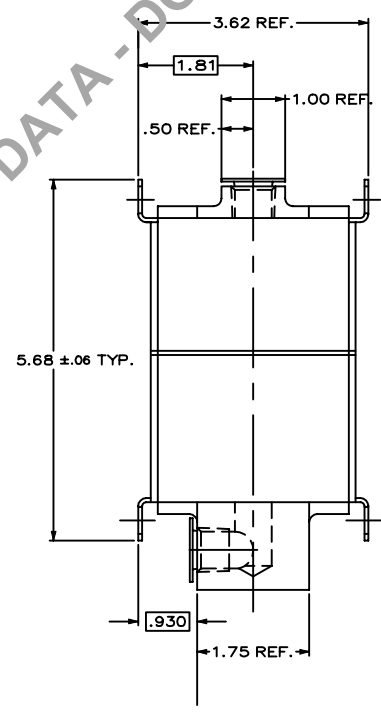
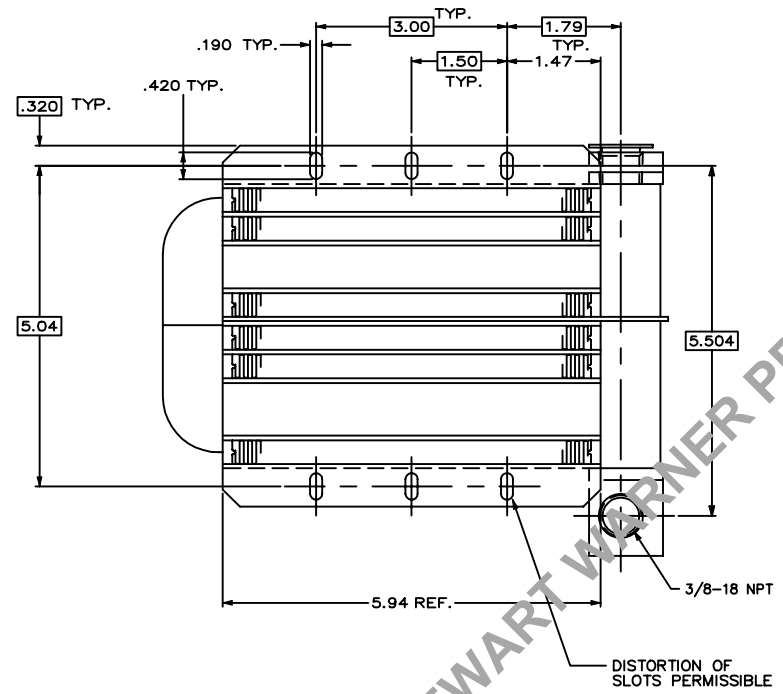
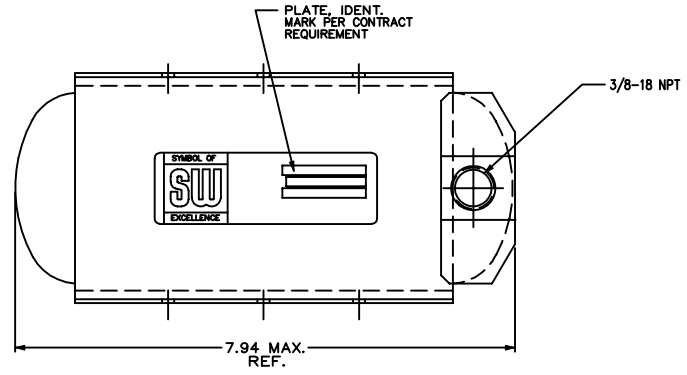

STEWART WARNER PROPRIETARY DATA - DO NOT DUPLICATE

8432S

THIS DRAWING IS PREPARED IN ACCORDANCE WITH:
 800-100-100 ENGINEERING DRAWING PRACTICES AND
 AND-174-A DIMENSIONING AND TOLERANCING FOR
 ENGINEERING DRAWINGS.

THE INFORMATION DISCLOSED HEREIN CONTAINS PROPRIETARY
 DATA OF STEWART-WARNER CORPORATION. NEITHER THIS DOC-
 UMENT NOR THE INFORMATION DISCLOSED HEREIN SHALL BE
 REPRODUCED OR TRANSMITTED IN ANY FORM OR BY ANY
 MEANS, ELECTRONIC OR MECHANICAL, INCLUDING PHOTOCOPYING,
 RECORDING, OR BY ANY INFORMATION STORAGE AND RETRIEVAL
 SYSTEM, WITHOUT THE WRITTEN PERMISSION OF STEWART-WARNER CORPORATION.

STEWART WARNER SOUTH WIND CORPORATION INDIANAPOLIS, INDIANA			
TITLE HEAT EXCHANGER OIL COOLER			
SIZE D	CAGE NO. 78385	DWG NO. 8432S	
SCALE	WT	SHEET	

FORM NO. 1453 REV. 12-80 8 7 6 5 4 3 2 1

Stewart Warner 8432S Calculated Heat Rejection

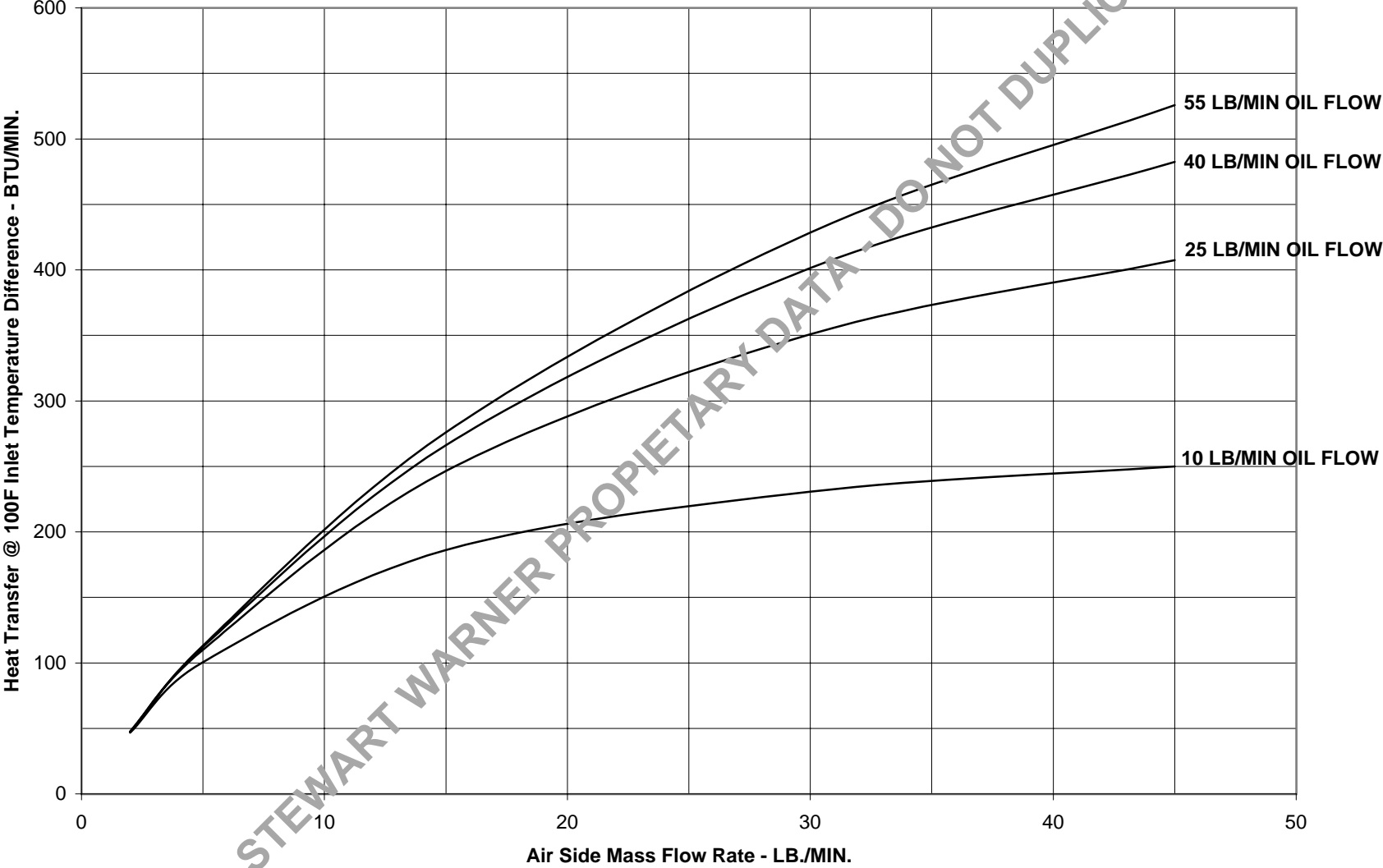

Stewart Warner 8432S Air Side Pressure Drop

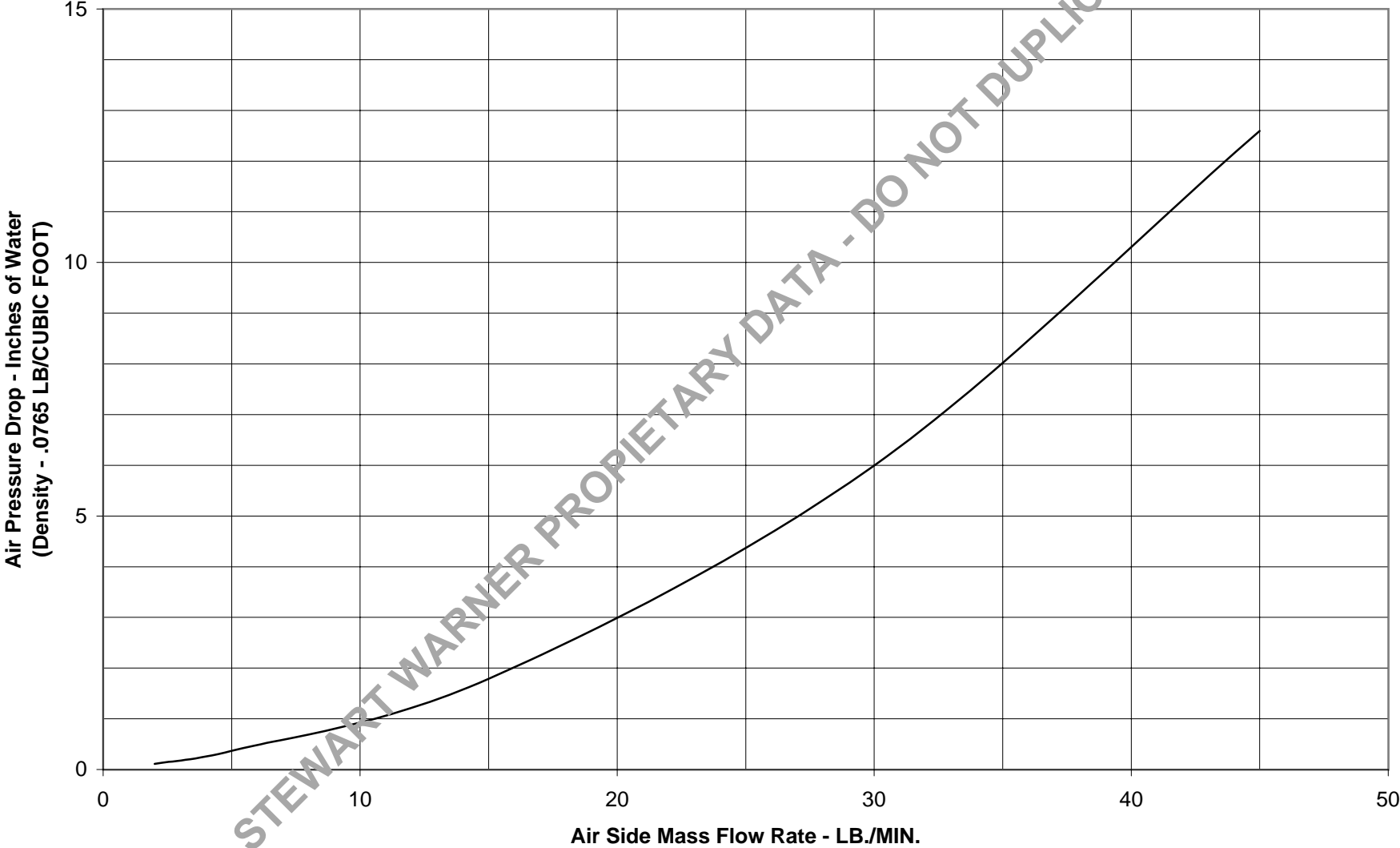

Stewart Warner 8432S Oil Side Pressure Drop

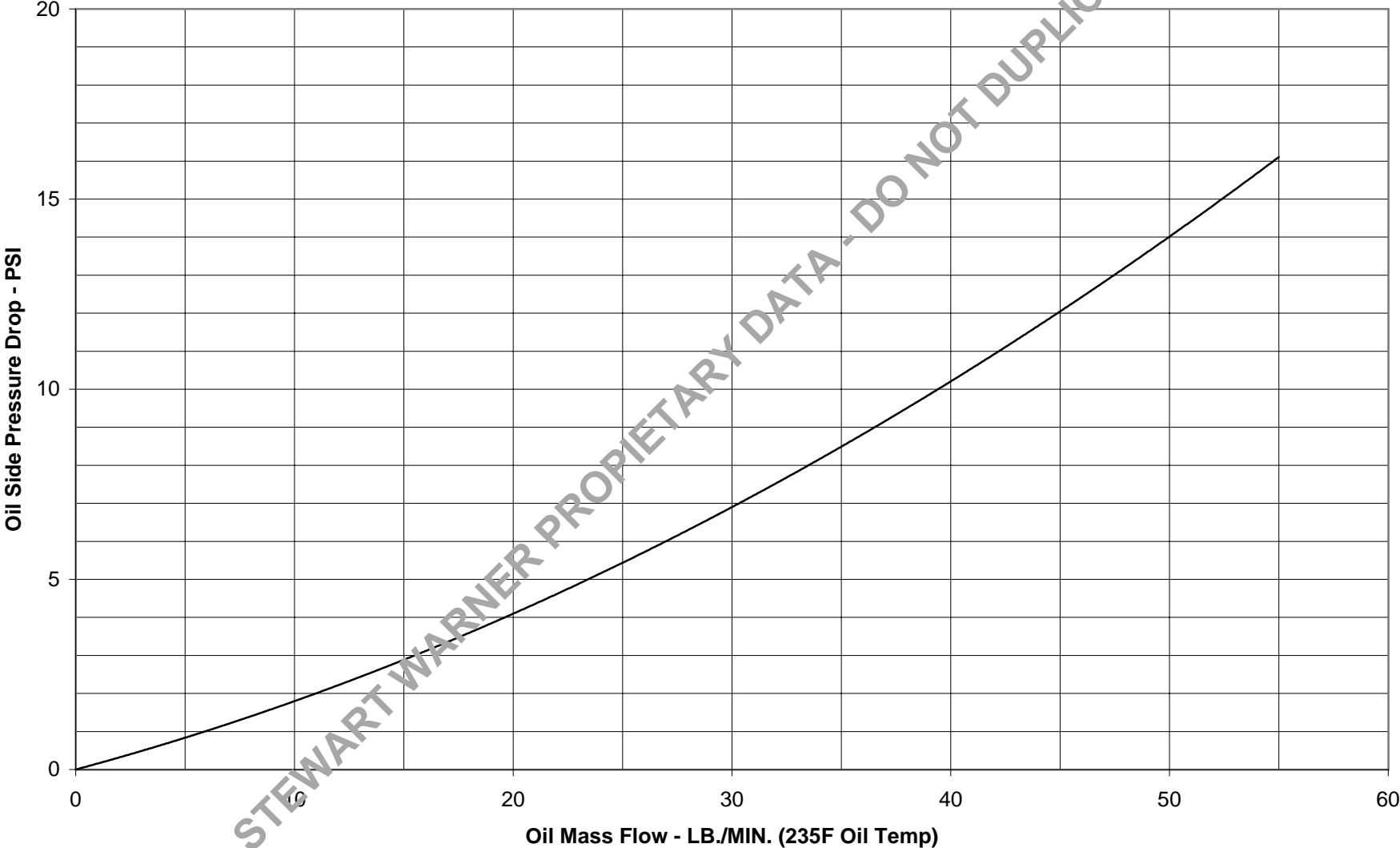

		REVISIONS	
ZONE	REV	DESCRIPTION	DATE
			960220 DH

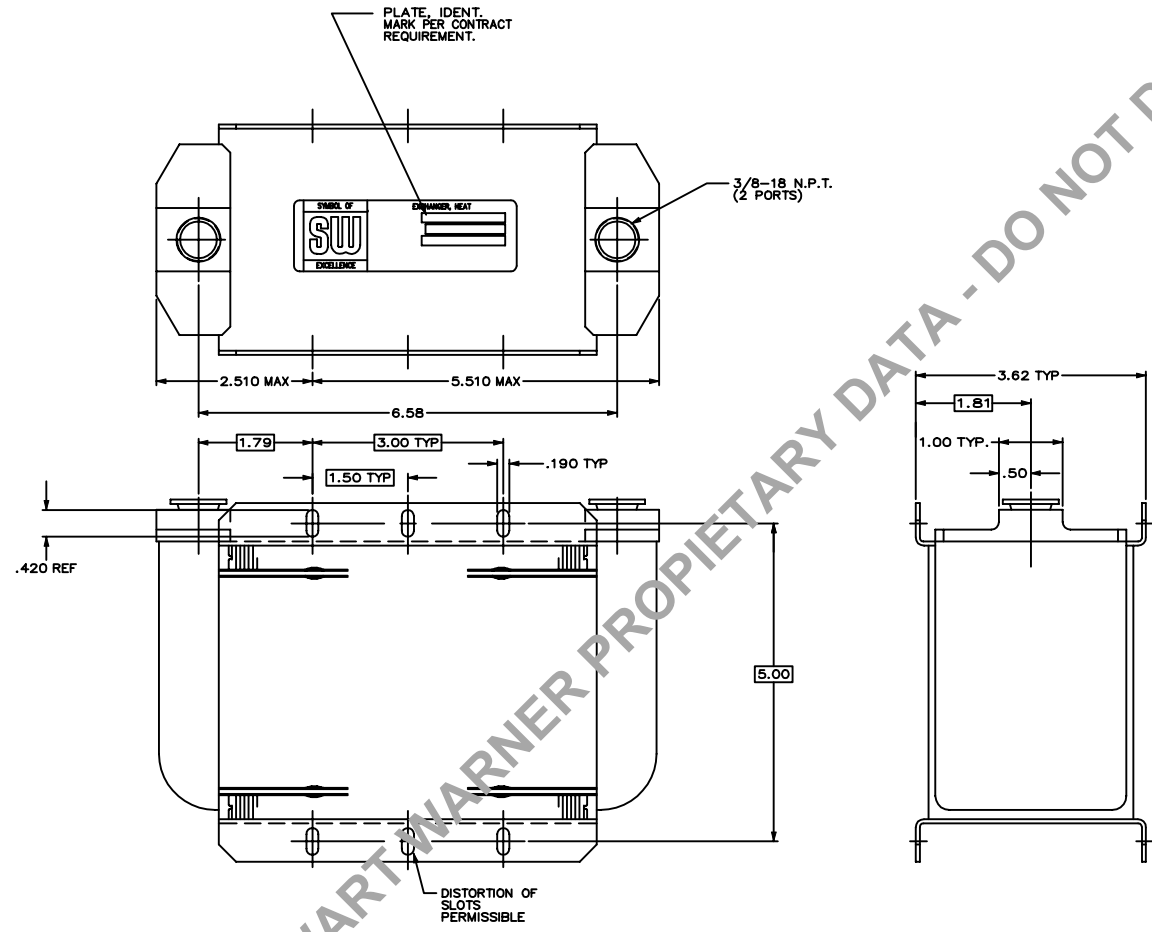

STEWART WARNER PROPRIETARY DATA - DO NOT DUPLICATE

10599R

THIS DRAWING IS PREPARED IN ACCORDANCE WITH:
 100-100-100 ENGINEERING DRAWING PRACTICES AND
 100-100-100 ENGINEERING AND TECHNOLOGY FOR
 ENGINEERING DRAWINGS.

THE INFORMATION DISCLOSED HEREIN CONTAINS PROPRIETARY
 DATA OF STEWART-WARNER CORPORATION. NEITHER THE DOC-
 UMENT NOR THE INFORMATION DISCLOSED HEREIN SHALL BE
 REPRODUCED OR TRANSMITTED IN ANY FORM OR BY ANY
 MEANS, ELECTRONIC OR MECHANICAL, INCLUDING PHOTOCOPYING,
 RECORDING, OR BY ANY INFORMATION STORAGE AND RETRIEVAL
 SYSTEM, WITHOUT PERMISSION IN WRITING BY STEWART-WARNER CORPORATION.

STEWART WARNER SOUTH WIND CORPORATION INDIANAPOLIS, INDIANA		
TITLE HEAT EXCHANGER OIL COOLER		
SIZE D	CAGE NO. 78385	DWG NO. 10599R
SCALE	WT	SHEET

Stewart Warner 10599R Calculated Heat Rejection

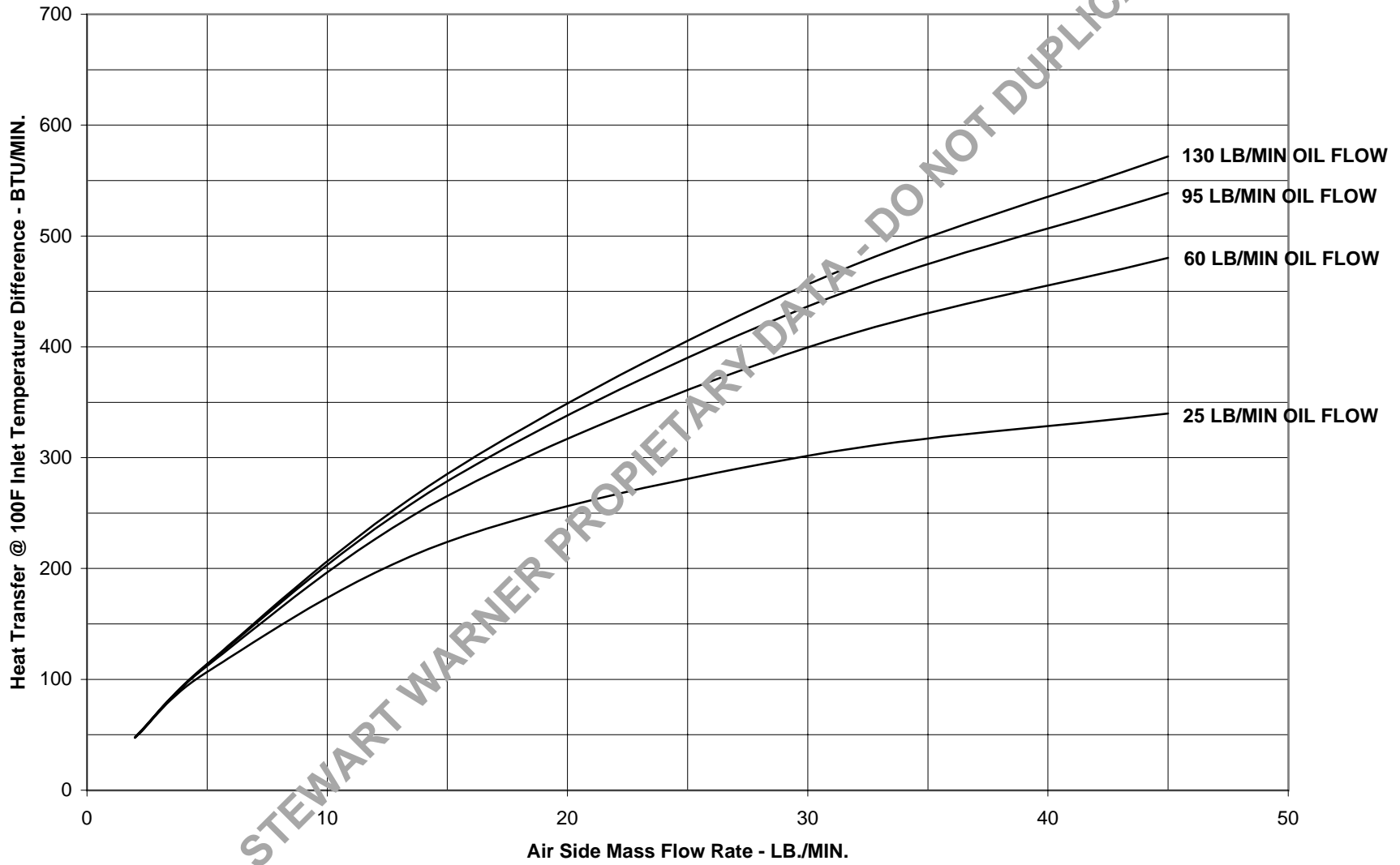

Stewart Warner 10599R Air Side Pressure Drop

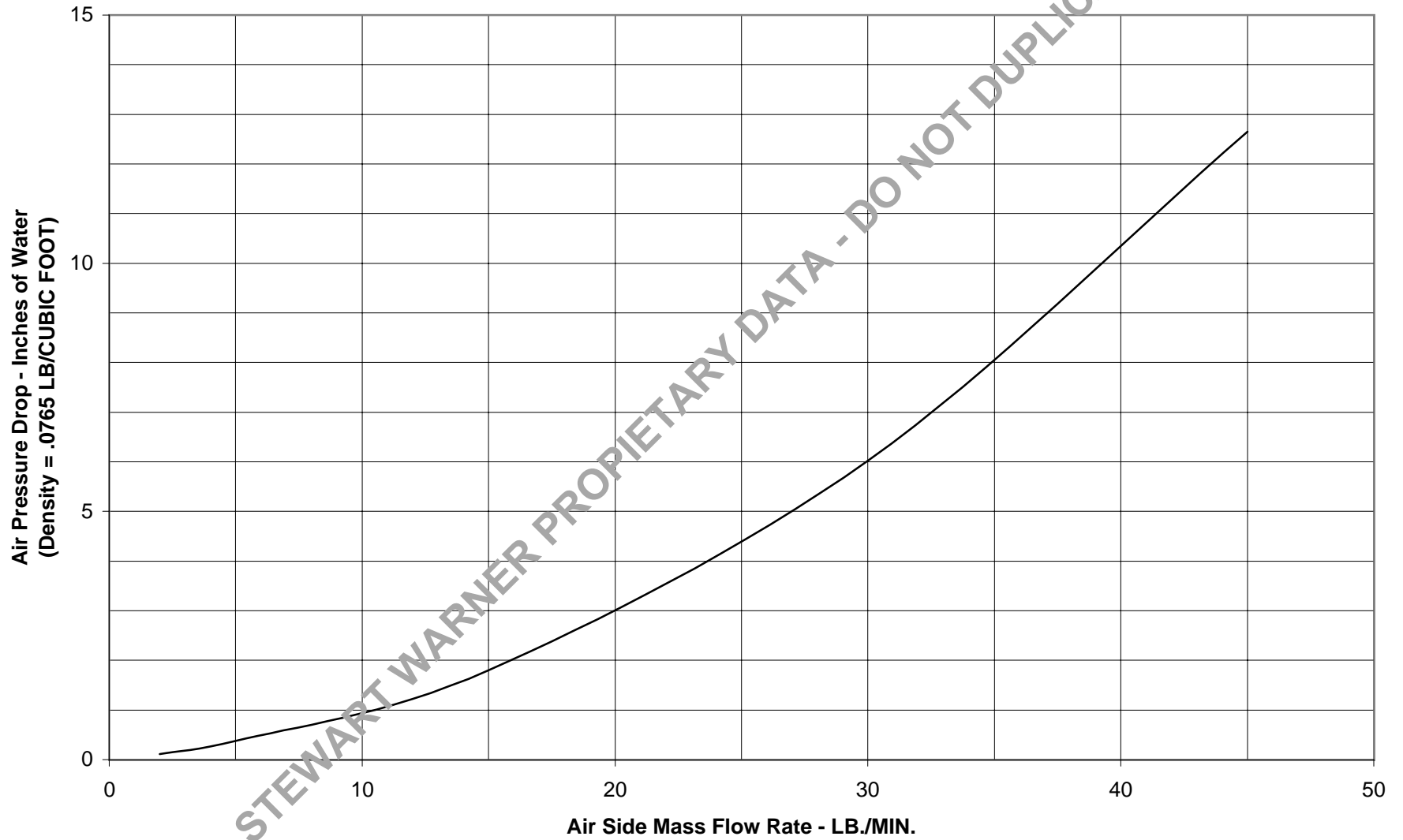

STEWART WARNER PROPRIETARY DATA - DO NOT DUPLICATE

Stewart Warner 10599R Oil Side Pressure Drop

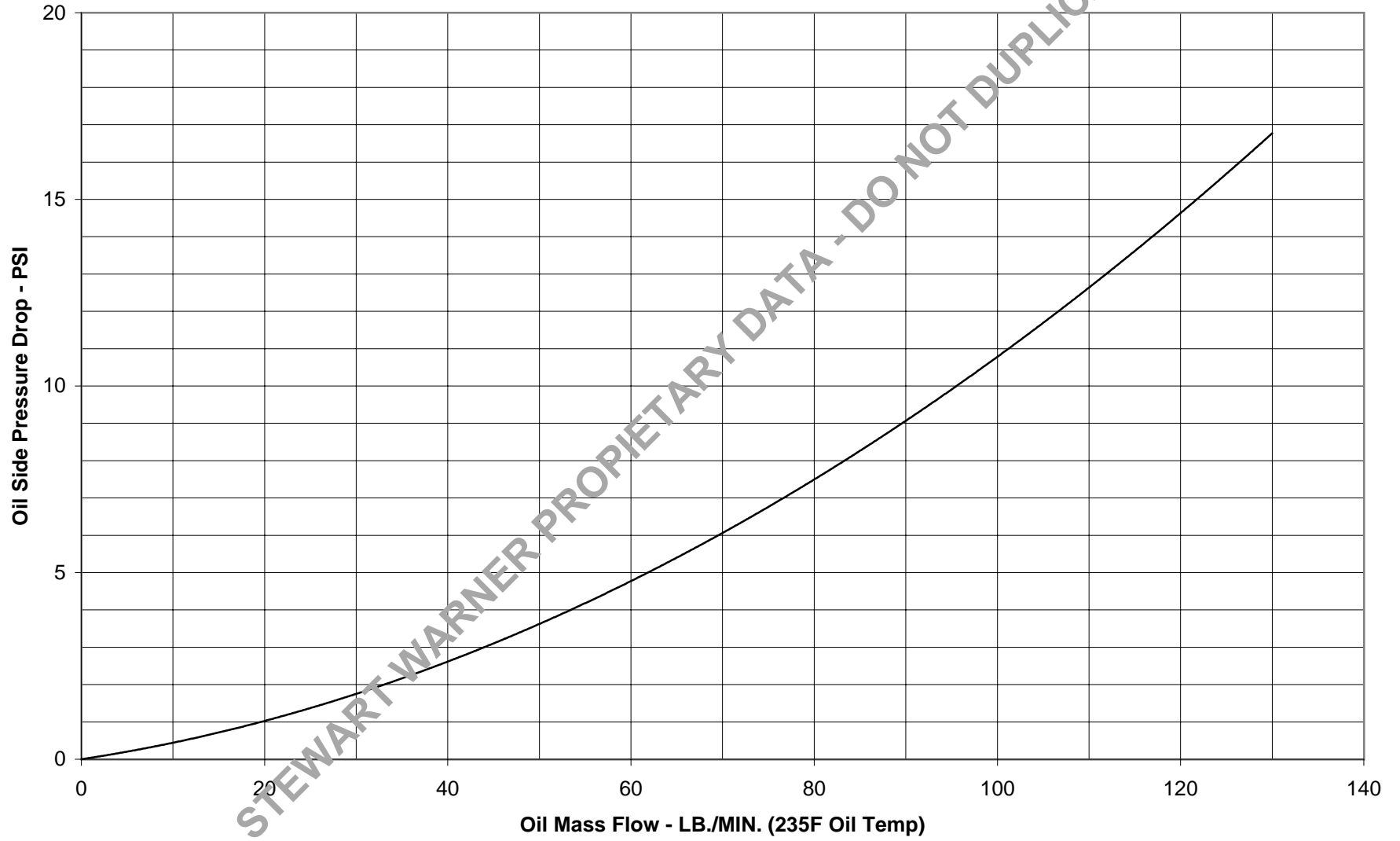

8 7 6 5 4 3 2 1

		REVISIONS			
ZONE	REV	DESCRIPTION	DATE	APPROVED	

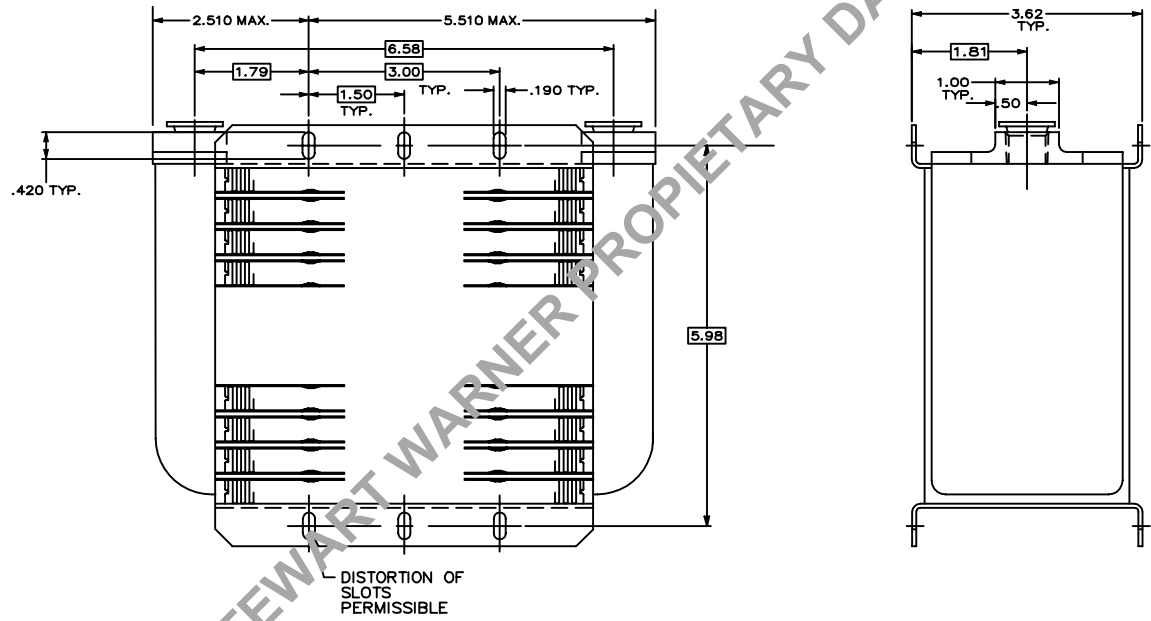
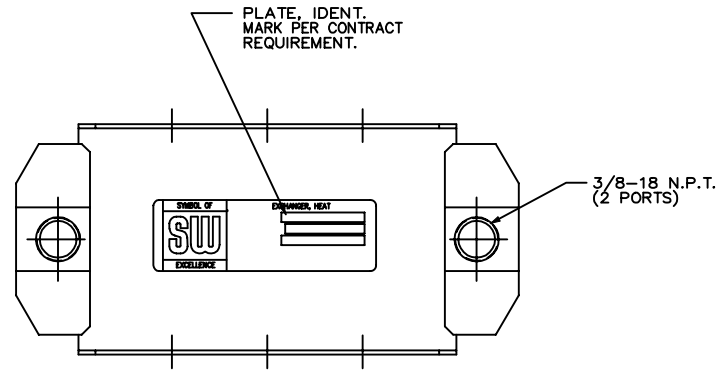

10610R

STEWART WARNER PROPRIETARY DATA - DO NOT DUPLICATE

STEWART WARNER SOUTH WIND CORPORATION INDIANAPOLIS, INDIANA			
TITLE HEAT EXCHANGER OIL COOLER			
SIZE D	CAGE NO. 78385	DWG NO. 10610R	
SCALE	WT	SHEET	

THIS DRAWING IS PREPARED IN ACCORDANCE WITH:
 DDG-STD-100 ENGINEERING DRAWING PRACTICES AND
 ANSI-Y14.5 ENGINEERING AND TECHNOLOGY FOR
 ENGINEERING DRAWINGS.

THE INFORMATION DISCLOSED HEREIN CONTAINS PROPRIETARY
 DATA OF STEWART-WARNER CORPORATION. NEITHER THE DOC-
 UMENT NOR THE INFORMATION DISCLOSED HEREIN SHALL BE
 REPRODUCED OR TRANSMITTED IN ANY FORM OR BY ANY
 MEANS, ELECTRONIC OR MECHANICAL, INCLUDING PHOTOCOPY-
 ING, RECORDING, OR BY ANY INFORMATION STORAGE AND
 RETRIEVAL SYSTEM, WITHOUT PERMISSION IN WRITING BY
 STEWART-WARNER CORPORATION.

FORM NO. 1453 REV. 12-86 8 7 6 5 4 3 2 1

Stewart Warner 10610R Calculated Heat Rejection

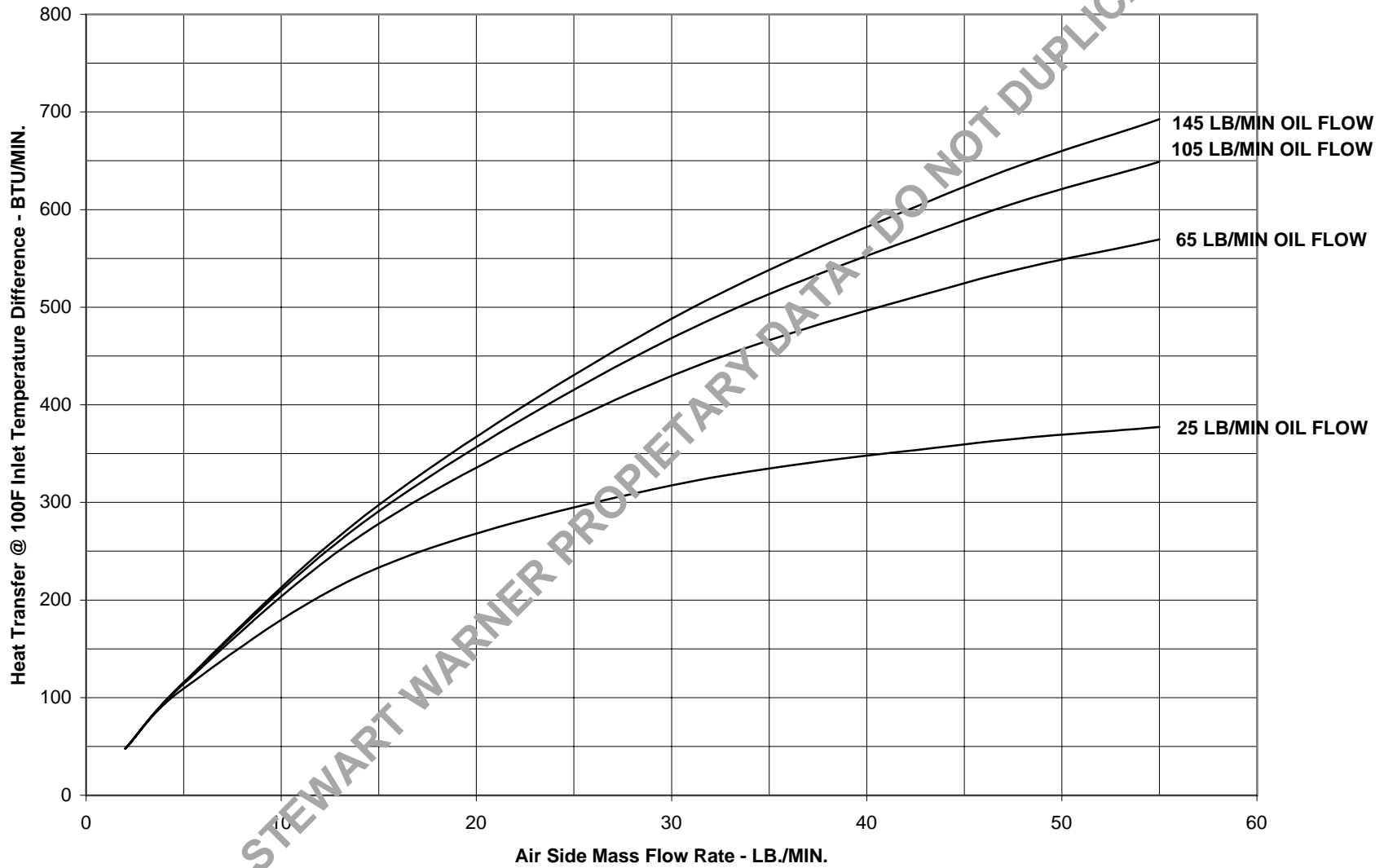

Stewart Warner 10610R Air Side Pressure Drop

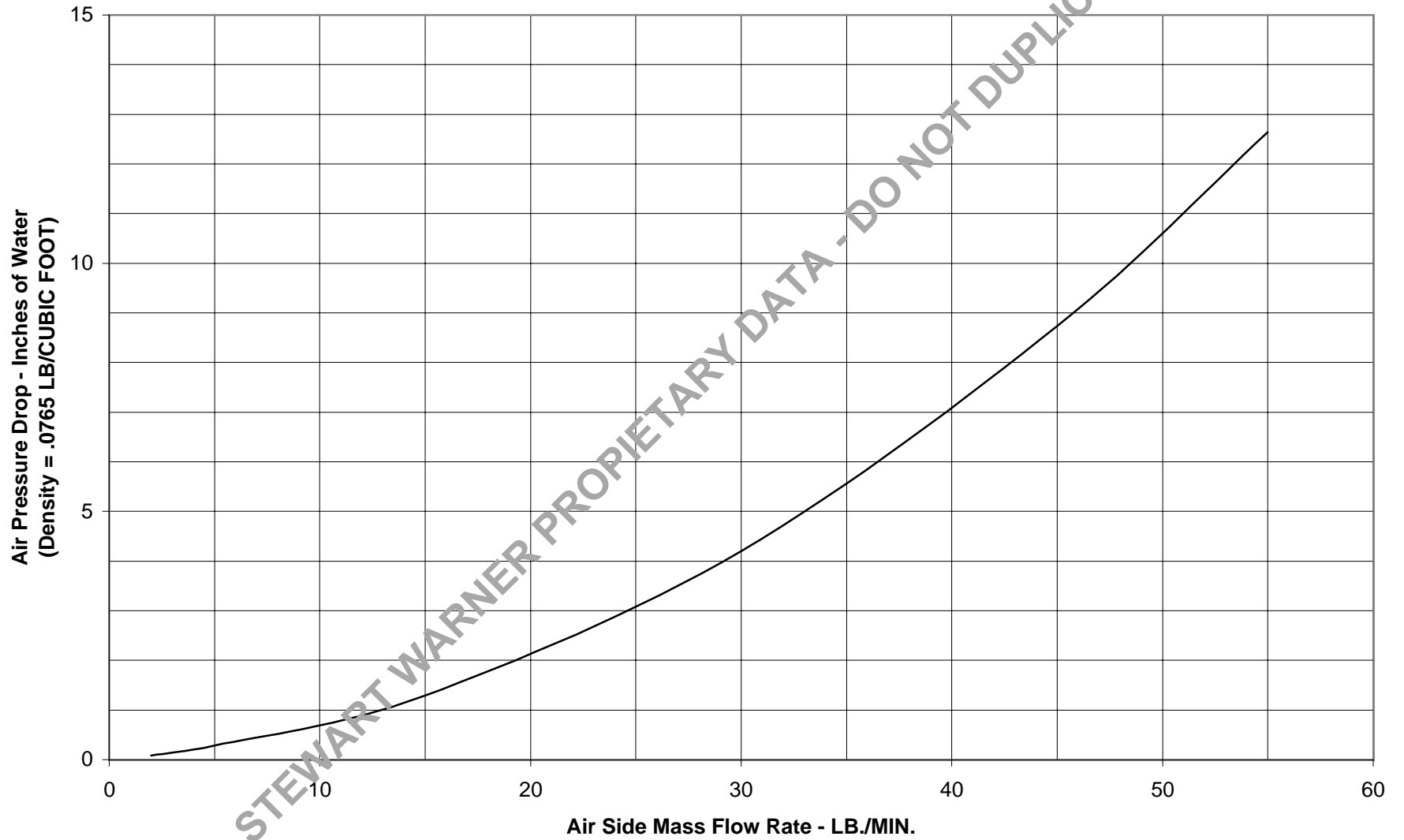

STEWART WARNER PROPRIETARY DATA - DO NOT DUPLICATE

Stewart Warner 10610R Oil Side Pressure Drop

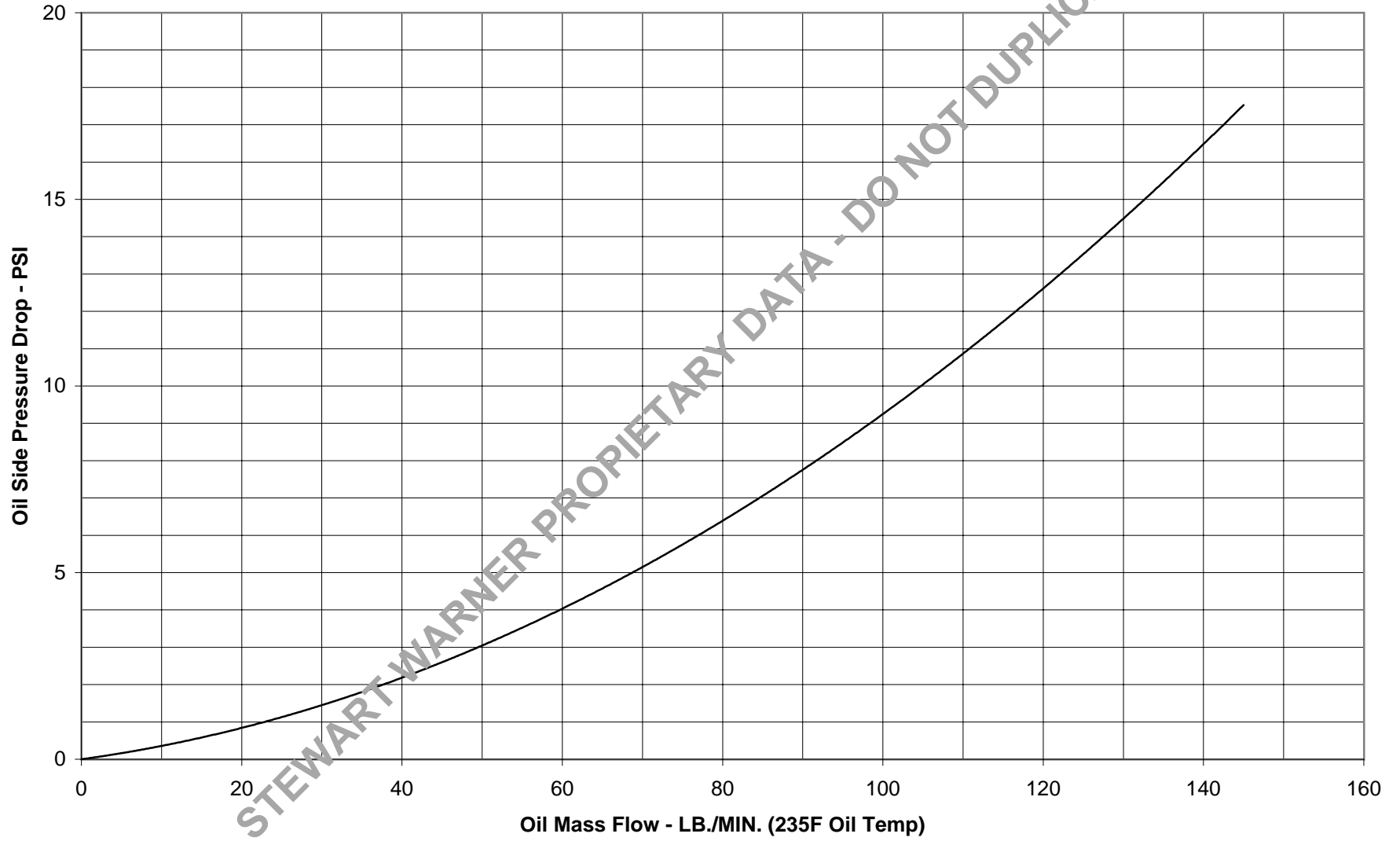

STEWART WARNER PROPRIETARY DATA - DO NOT DUPLICATE

8 7 6 5 4 3 2 1

D
C
B
A

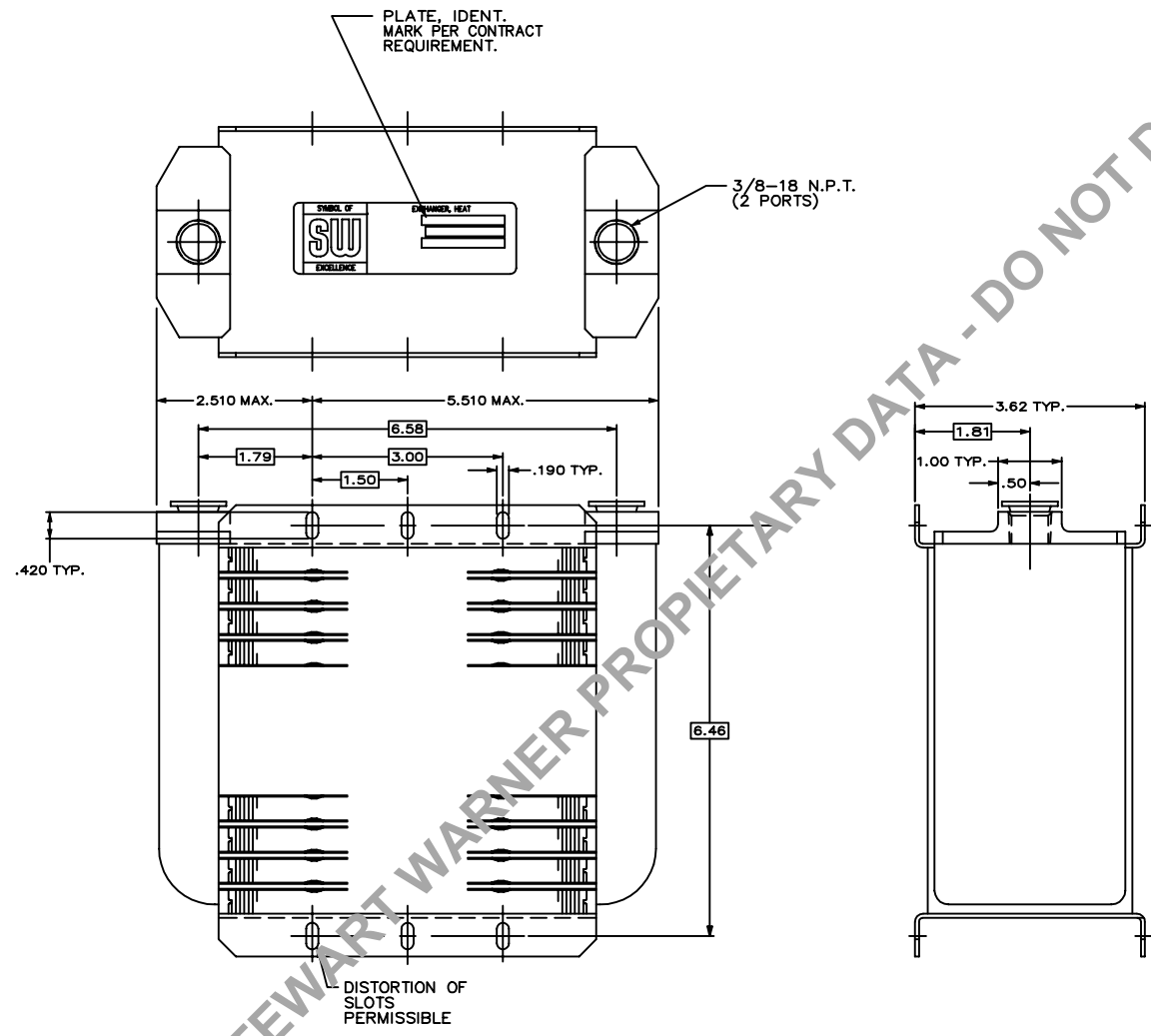

REVISONS		DESCRIPTION	DATE	APPROVED
ZONE	REV			

10611R

STEWART WARNER SOUTH WIND CORPORATION
INDIANAPOLIS, INDIANA

TITLE
HEAT EXCHANGER OIL COOLER

SIZE D	CAGE NO. 78385	DWG NO. 10611R
-----------	-------------------	-------------------

SCALE	WT	SHEET
-------	----	-------

THIS DRAWING IS PREPARED IN ACCORDANCE WITH:
DOD-STD-30 ENGINEERING DRAWING PRACTICES AND
ANSI-Y14.5 ENGINEERING AND TECHNOLOGY FOR
ENGINEERING DRAWINGS.

THE INFORMATION DISCLOSED HEREIN CONTAINS PROPRIETARY
DATA OF STEWART-WARNER CORPORATION. NEITHER THE DOC-
UMENT NOR THE INFORMATION DISCLOSED HEREIN SHALL BE
REPRODUCED OR TRANSMITTED IN ANY FORM OR BY ANY
MEANS, ELECTRONIC OR MECHANICAL, INCLUDING PHOTOCOPYING,
RECORDING, OR BY ANY INFORMATION STORAGE AND RETRIEVAL
SYSTEM, WITHOUT PERMISSION IN WRITING BY STEWART-WARNER CORPORATION.

FORM NO. 1453 REV. 12-80 8 7 6 5 4 3 2 1

Stewart Warner 10611R Calculated Heat Rejection

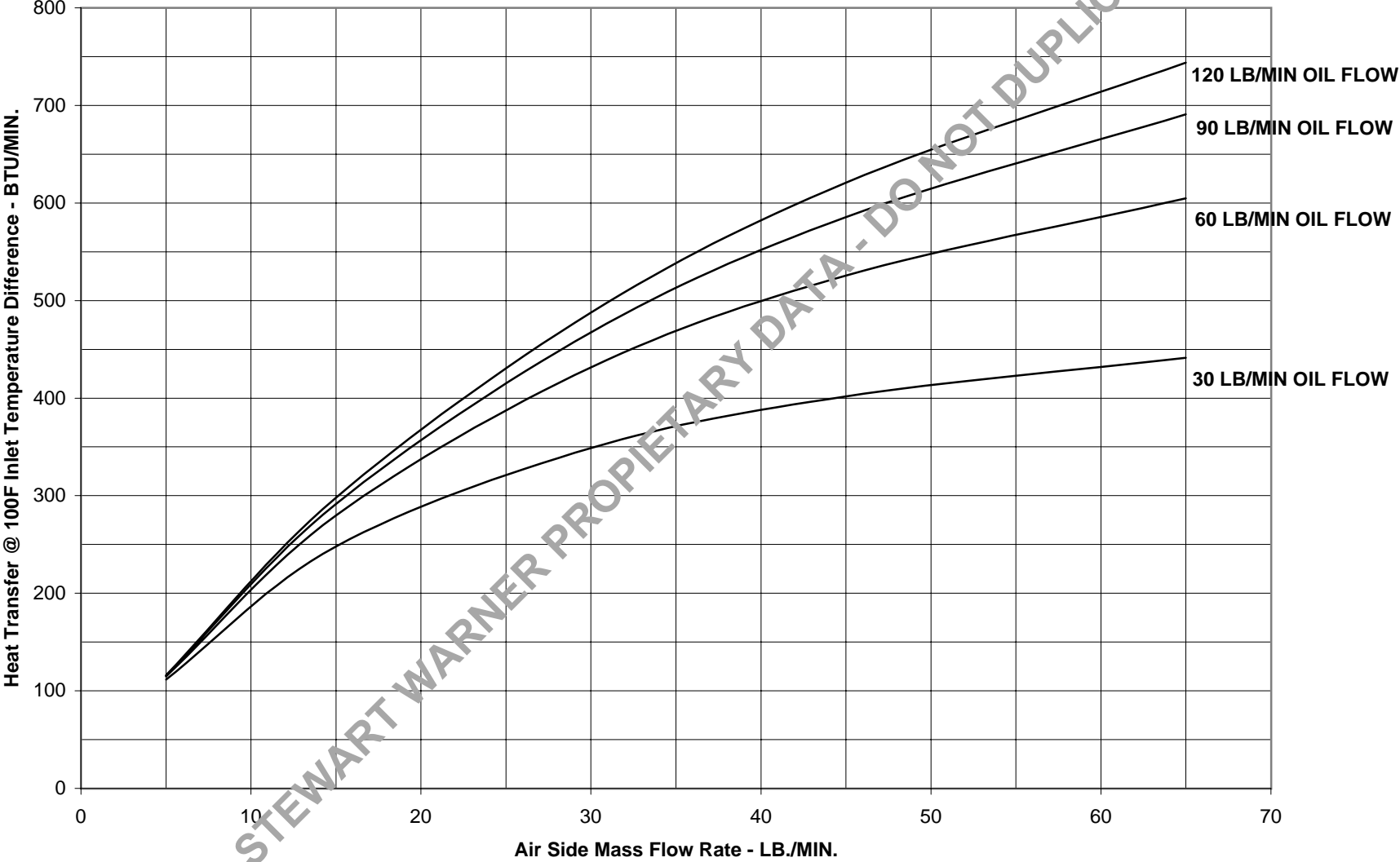

Stewart Warner 10611R Air Side Pressure Drop

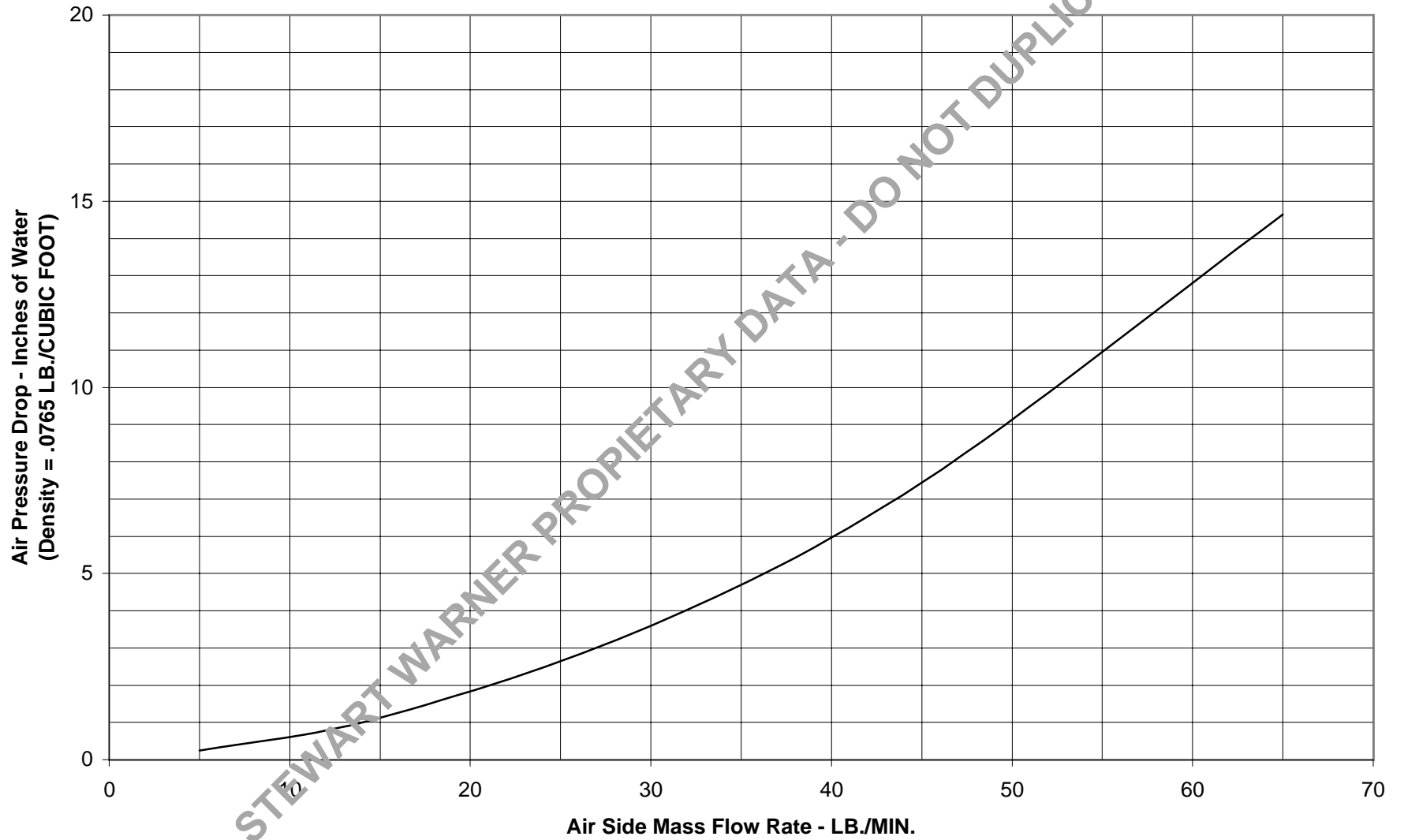

STEWART WARNER PROPRIETARY DATA - DO NOT DUPLICATE

Stewart Warner 10611R Oil Side Pressure Drop

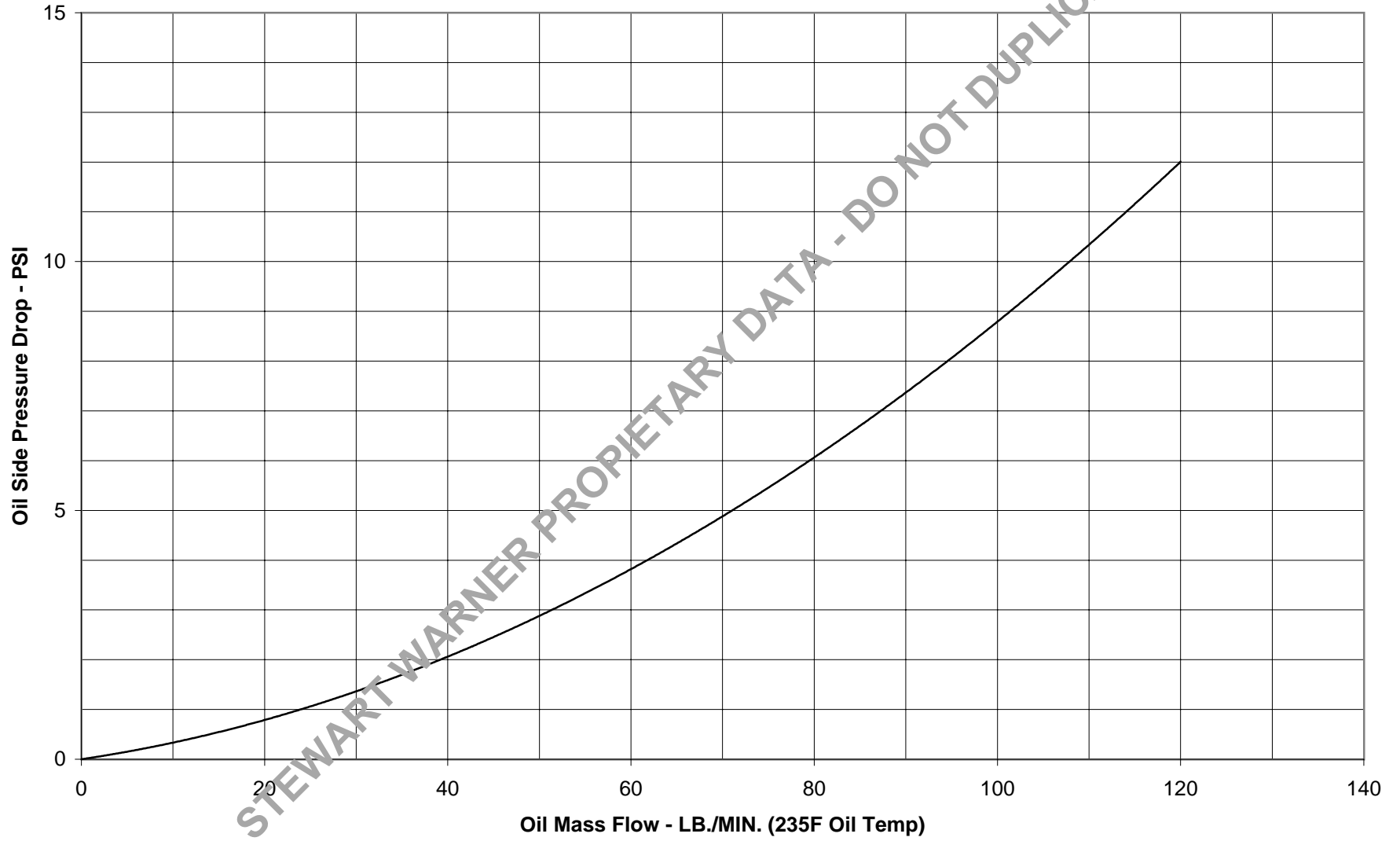

STEWART WARNER PROPRIETARY DATA - DO NOT DUPLICATE

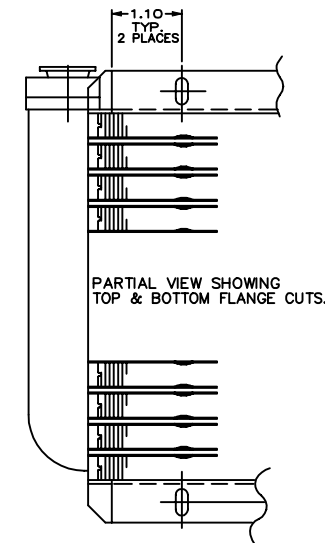
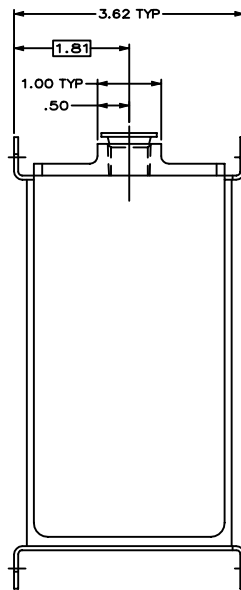
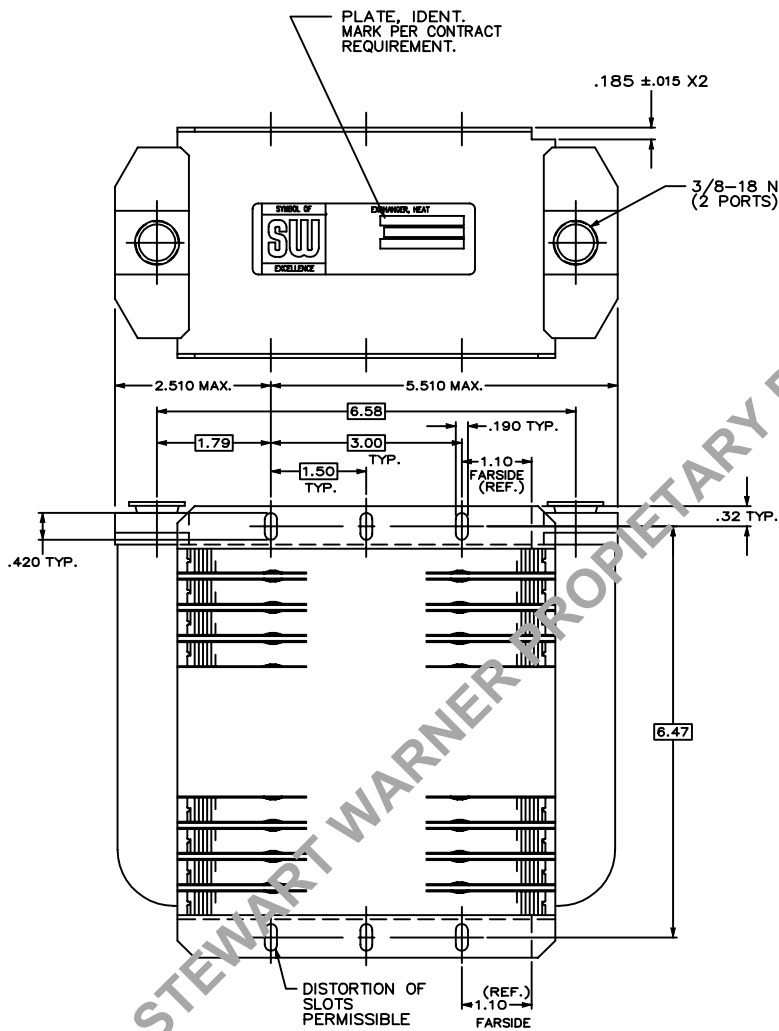

ZONE		REV	DESCRIPTION	DATE	APPROVED

10611S

THIS DRAWING IS PREPARED IN ACCORDANCE WITH 800-50-100 ENGINEERING DRAWING PRACTICES AND ANSI-Y14.5 DIMENSIONING AND TOLERANCING FOR ENGINEERING DRAWINGS.

THE INFORMATION INCLUDED HEREIN CONTAINS PROPRIETARY DATA OF STEWART-WARNER CORPORATION. NEITHER THIS DOCUMENT NOR THE INFORMATION DISCLOSED HEREIN SHALL BE REPRODUCED OR TRANSMITTED IN OTHER DOCUMENTS OR USED FOR MANUFACTURING PURPOSES OR DISCLOSED TO OTHERS FOR ANY PURPOSE EXCEPT AS SPECIFICALLY AUTHORIZED IN WRITING BY STEWART-WARNER CORPORATION.

STEWART WARNER SOUTH WIND CORPORATION INDIANAPOLIS, INDIANA		
TITLE HEAT EXCHANGER OIL COOLER		
SIZE D	CAGE NO. 78385	DWG NO. 10611S
SCALE	WT	SHEET

Stewart Warner 10611S Calculated Heat Rejection

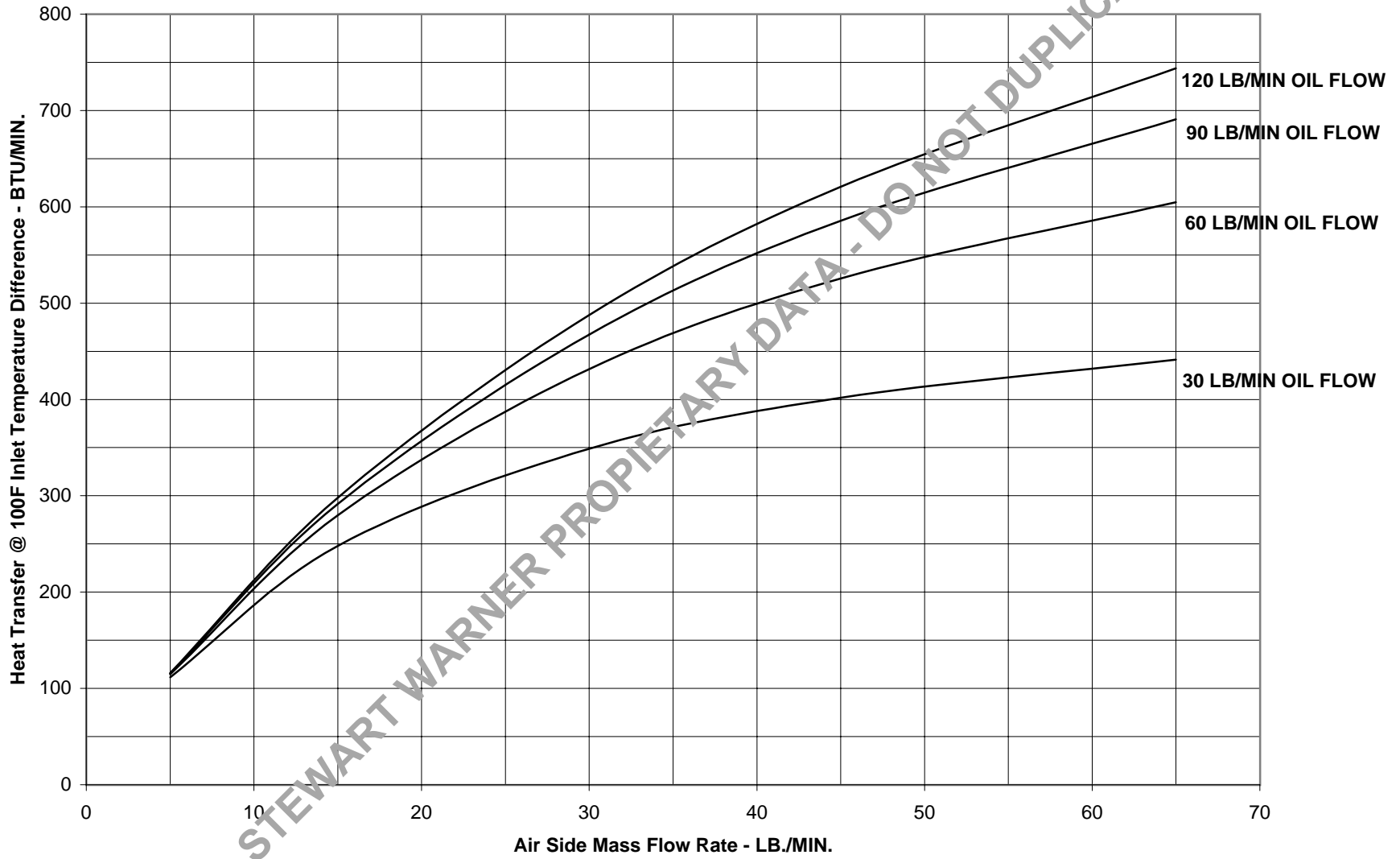

Stewart Warner 10611S Air Side Pressure Drop

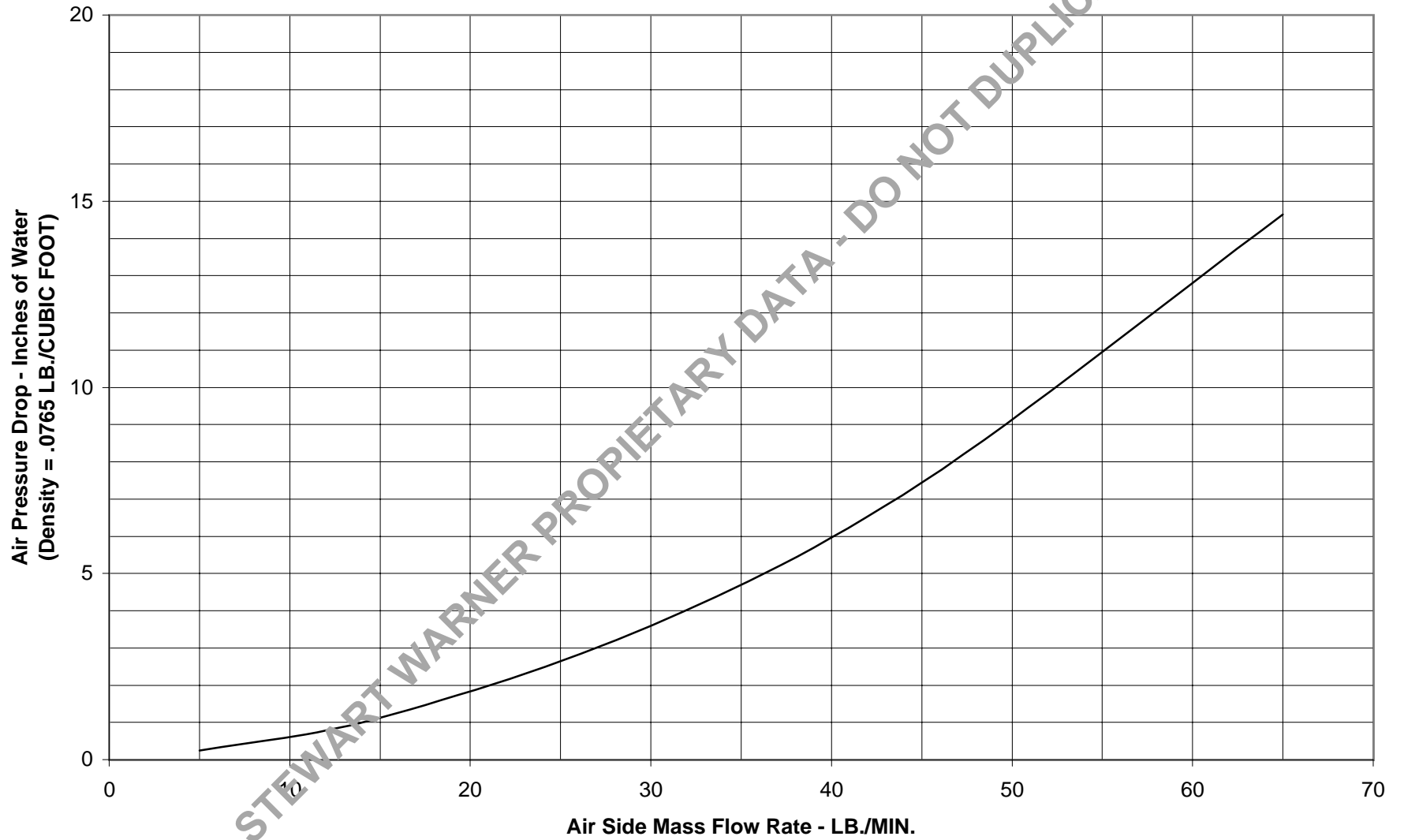

Stewart Warner 10611S Oil Side Pressure Drop

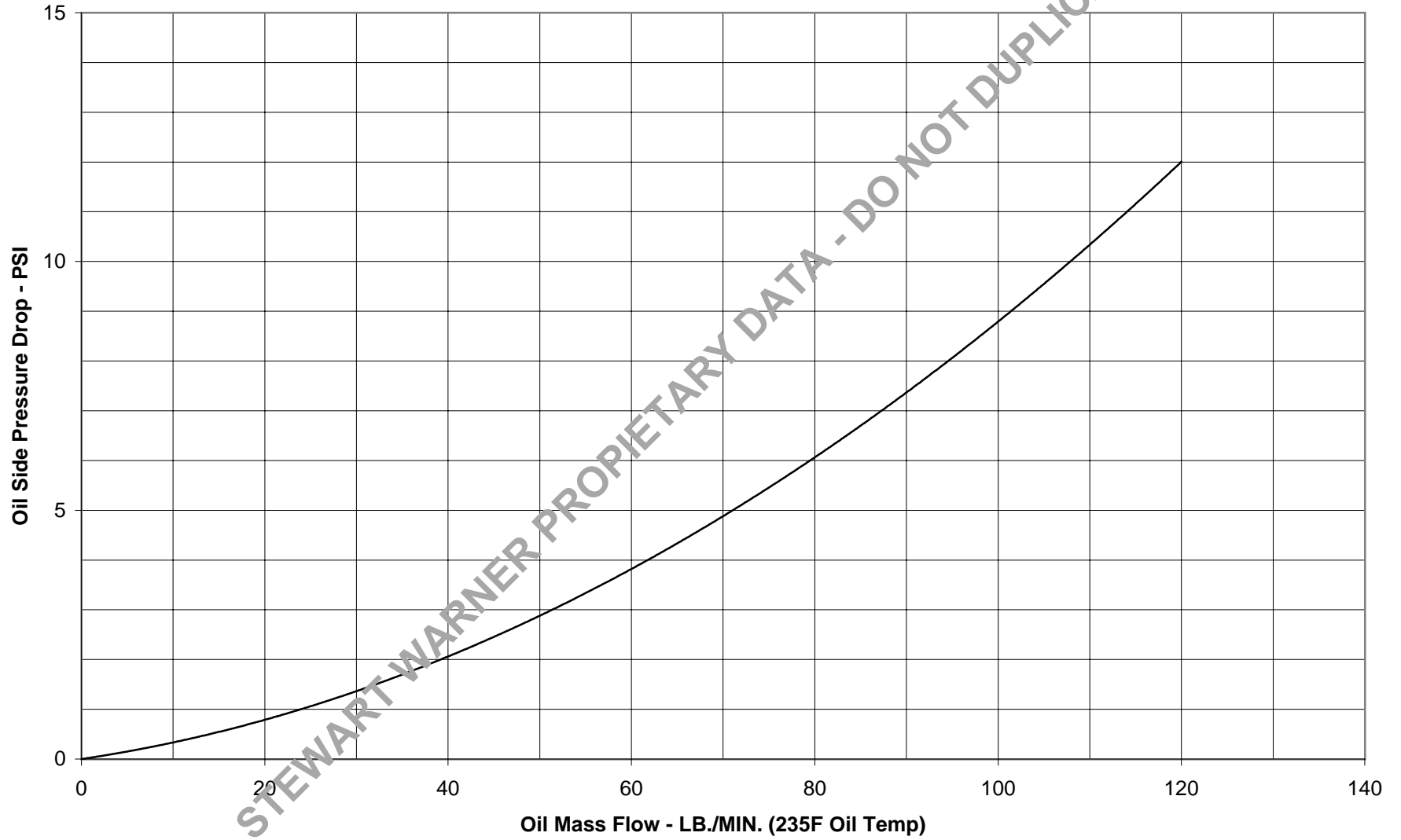

8 7 6 5 4 3 2 1

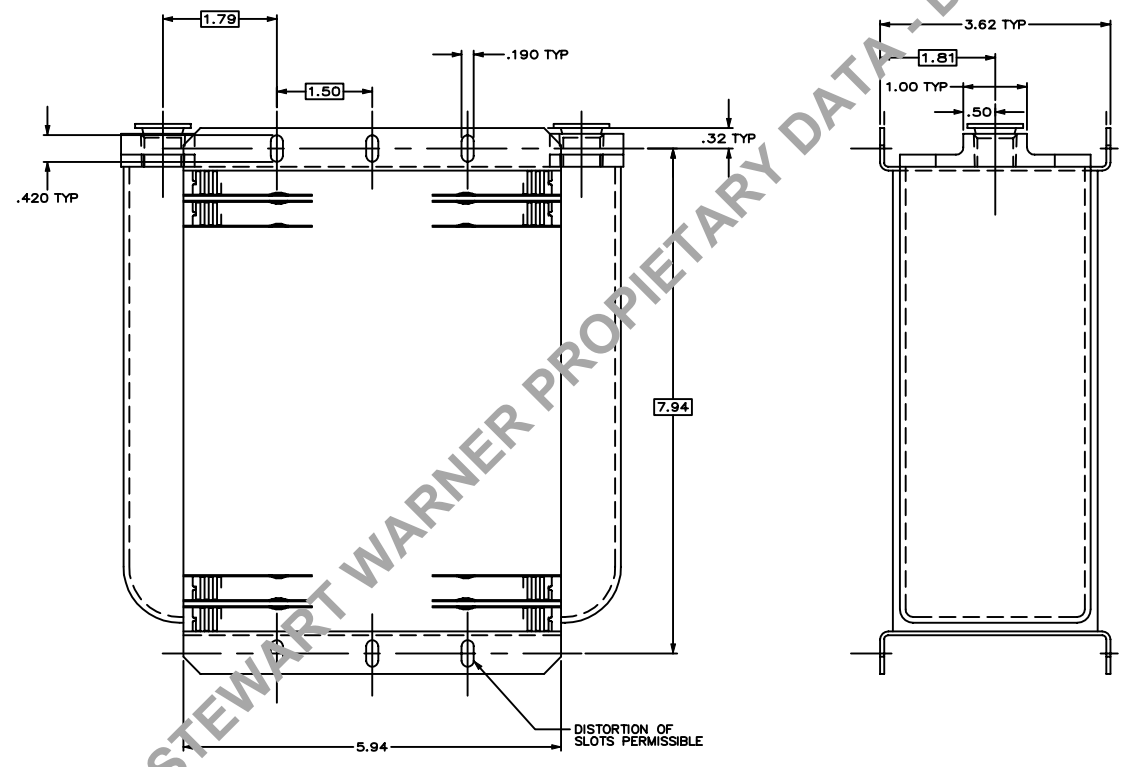
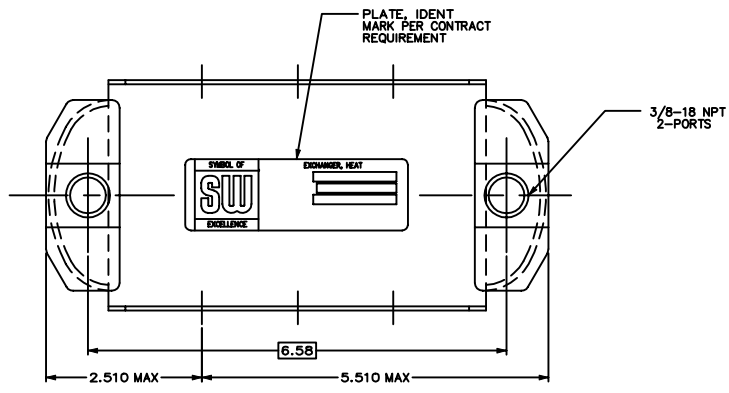

		REVISIONS			
ZONE	REV	DESCRIPTION	DATE	APPROVED	

10614R

STEWART WARNER SOUTH WIND CORPORATION INDIANAPOLIS, INDIANA			
TITLE HEAT EXCHANGER OIL COOLER			
SIZE D	CAGE NO. 78385	DWG NO. 10614R	
SCALE	WT	SHEET	

THIS DRAWING IS PREPARED IN ACCORDANCE WITH:
DOD-STD-360 ENGINEERING DRAWING PRACTICES AND
ASME-11.4 DIMENSIONING AND TOLERANCING FOR
ENGINEERING DRAWINGS.

THE INFORMATION DISCLOSED HEREIN CONTAINS PROPRIETARY
DATA OF STEWART-WARNER CORPORATION. NEITHER THE DOC-
UMENT NOR THE INFORMATION DISCLOSED HEREIN SHALL BE
REPRODUCED OR TRANSMITTED TO OTHER INDIVIDUALS OR USED
FOR MANUFACTURING PURPOSES OR DISCLOSED TO OTHERS
FOR ANY PURPOSE, EXCEPT AS SPECIFICALLY AUTHORIZED IN
WRITING BY STEWART-WARNER CORPORATION.

FORM NO. 1453 8 7 6 5 4 3 2 1 REV. 12-80

Stewart Warner 10614R Calculated Heat Rejection

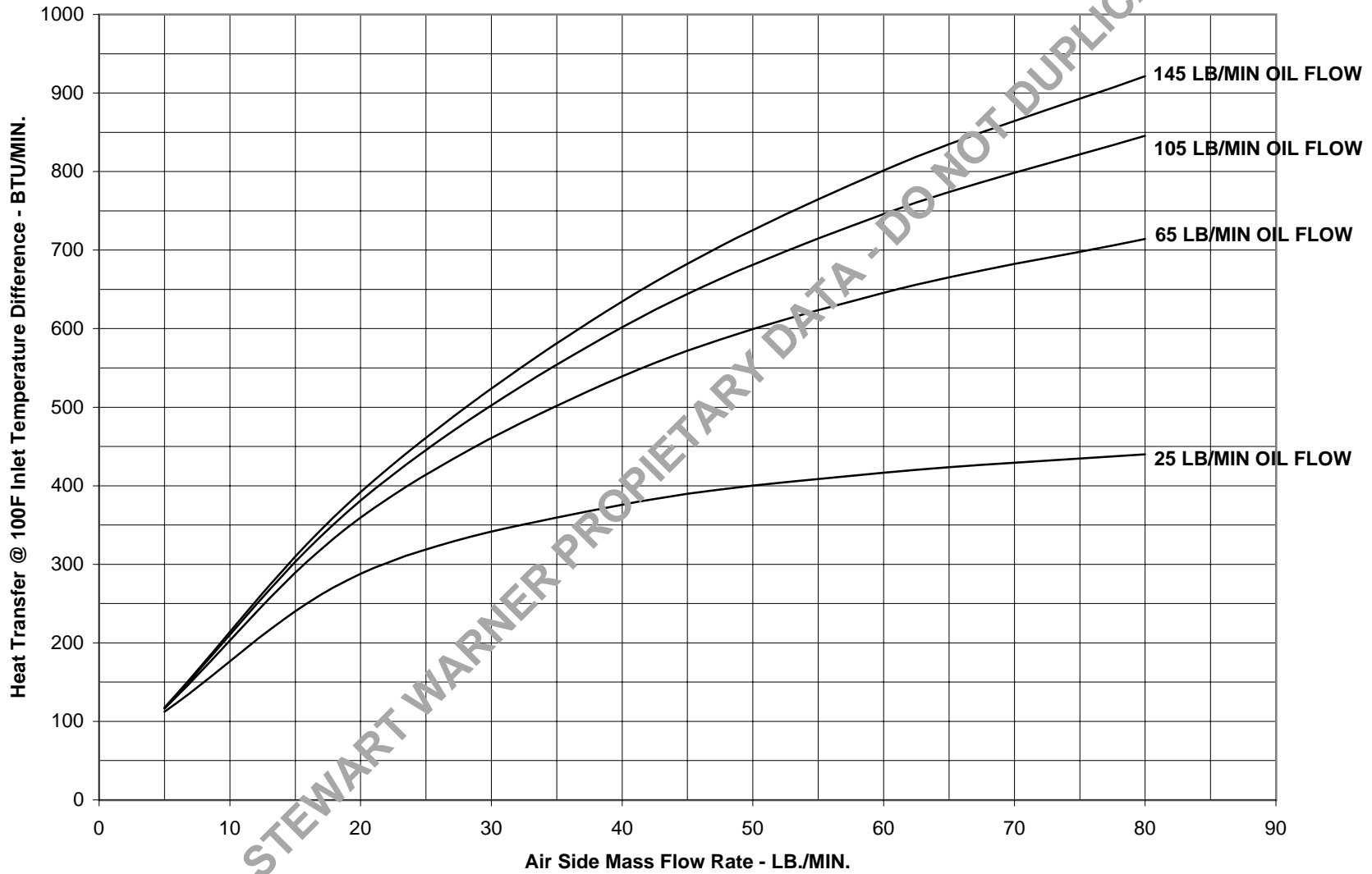

Stewart Warner 10614R Air Side Pressure Drop

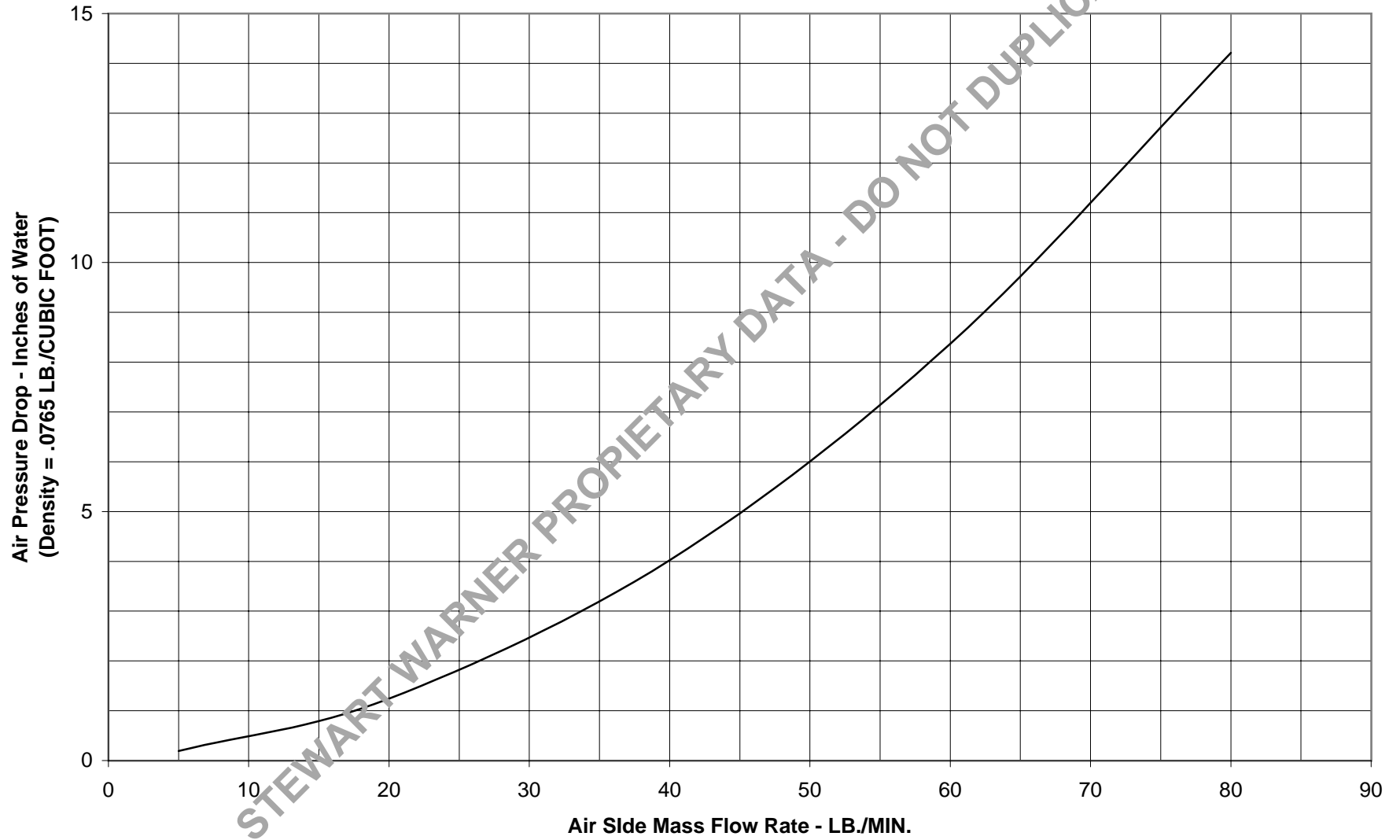

Stewart Warner 10614R Oil Side Pressure Drop

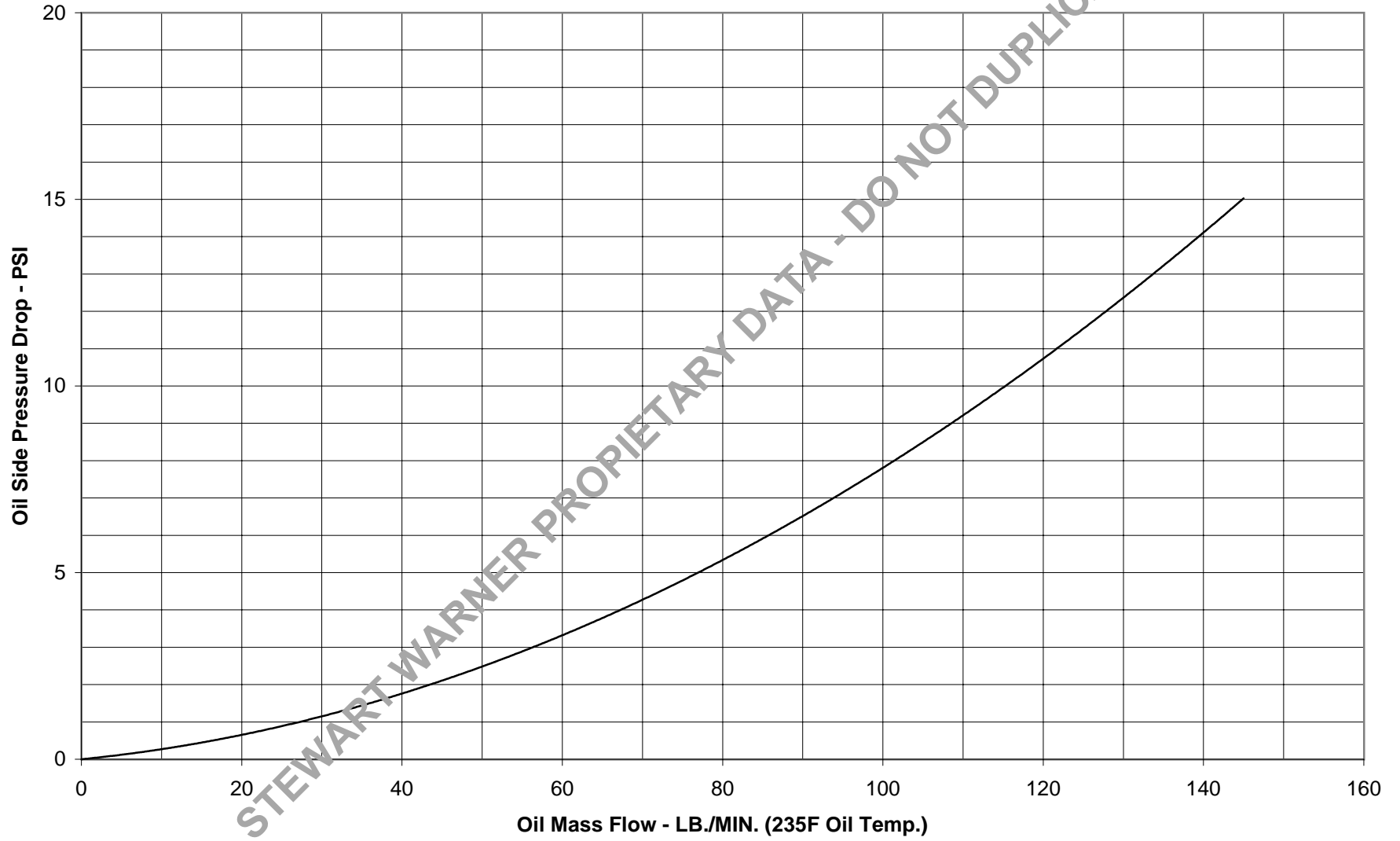

STEWART WARNER PROPRIETARY DATA - DO NOT DUPLICATE

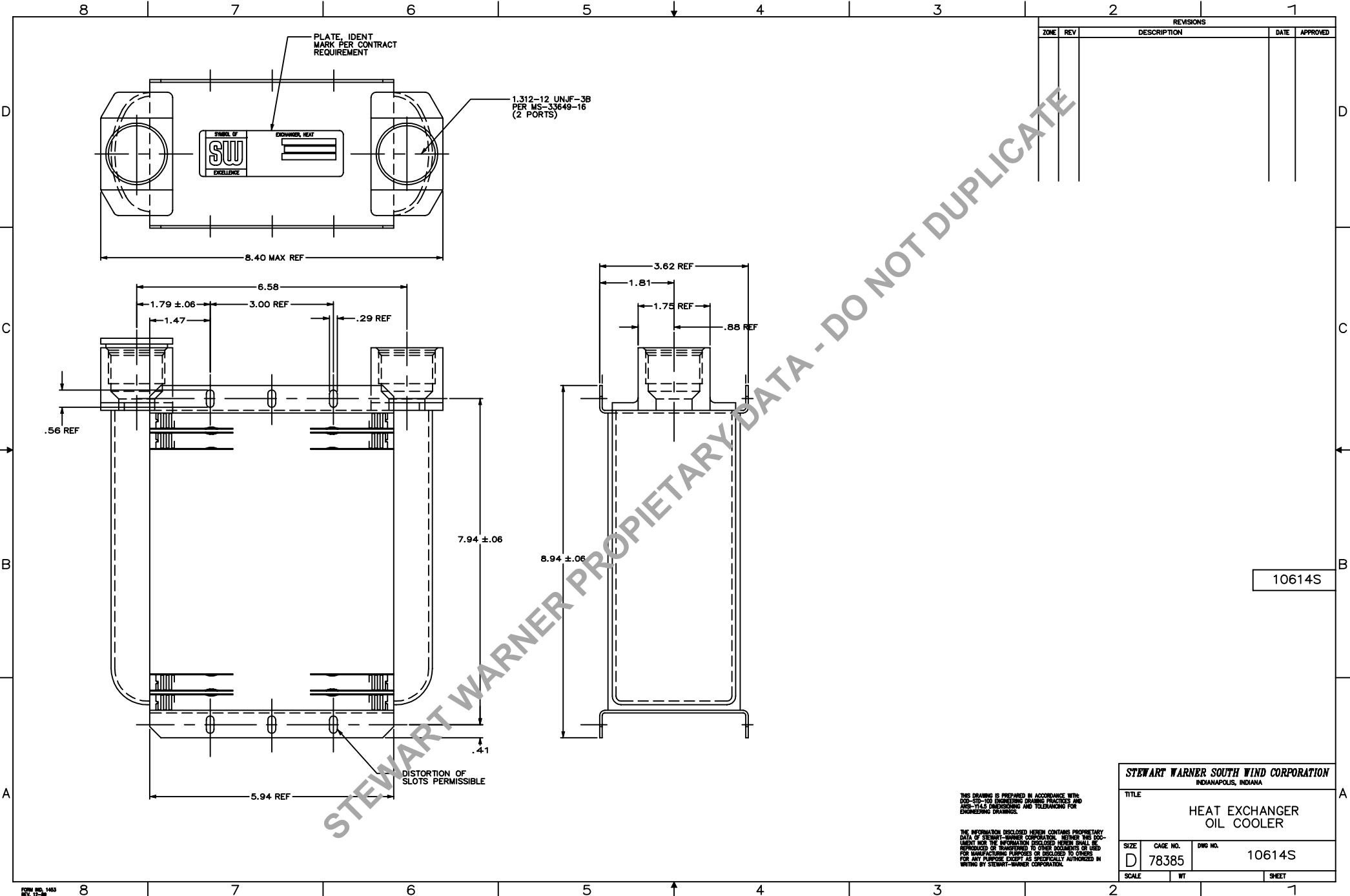

		REVISIONS			
ZONE	REV	DESCRIPTION	DATE	APPROVED	

10614S

THIS DRAWING IS PREPARED IN ACCORDANCE WITH
 D20-200-100 ENGINEERING DRAWING PRACTICES AND
 AS-114.5 DIMENSIONING AND TOLERANCING FOR
 ENGINEERING DRAWINGS.

THE INFORMATION DISCLOSED HEREIN CONTAINS PROPRIETARY
 DATA OF STEWART-WARNER CORPORATION. REUSE OF THIS
 DOCUMENT WITH THE INFORMATION DISCLOSED HEREIN SHALL BE
 REPRODUCED OR TRANSMITTED TO OTHER PERSONS OR USED
 FOR MANUFACTURING PURPOSES OR DISCLOSED TO OTHERS
 FOR ANY PURPOSE EXCEPT AS SPECIFICALLY AUTHORIZED IN
 WRITING BY STEWART-WARNER CORPORATION.

STEWART WARNER SOUTH WIND CORPORATION INDIANAPOLIS, INDIANA			
TITLE HEAT EXCHANGER OIL COOLER			
SIZE D	CAGE NO. 78385	DWG NO. 10614S	
SCALE	WT	SHEET	

Stewart Warner 10614S Calculated Heat Rejection

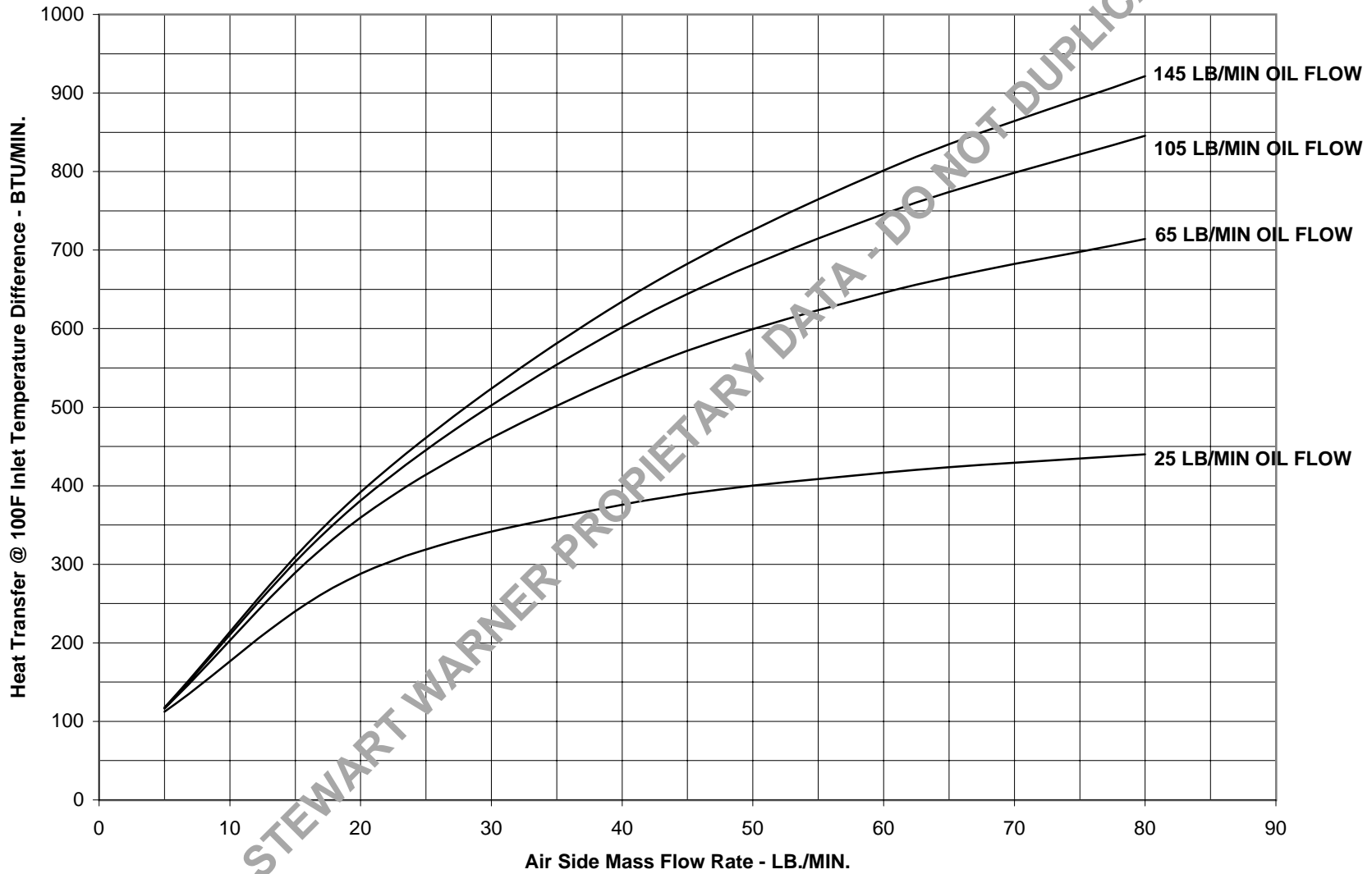

Stewart Warner 10614S Air Side Pressure Drop

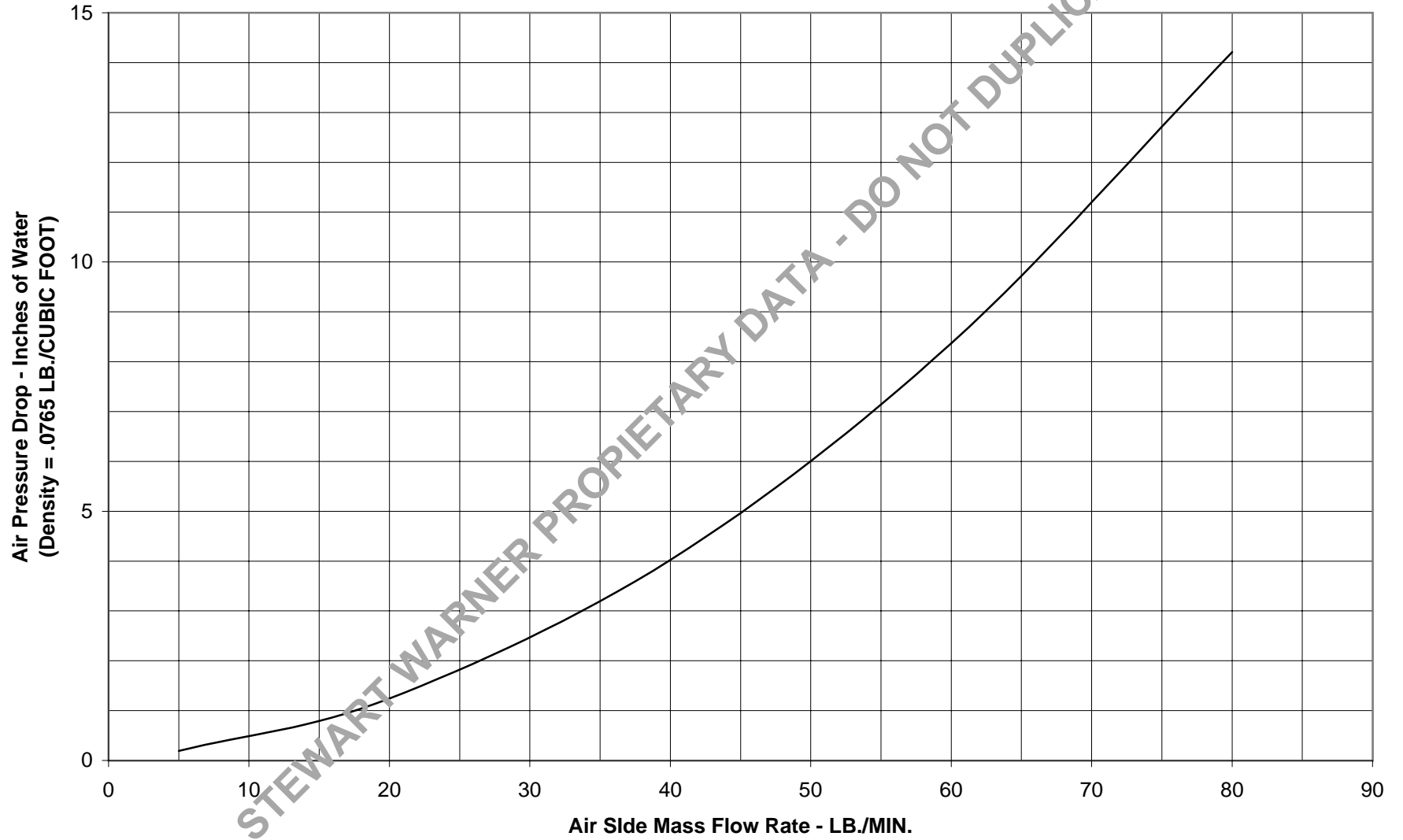

Stewart Warner 10614S Oil Side Pressure Drop

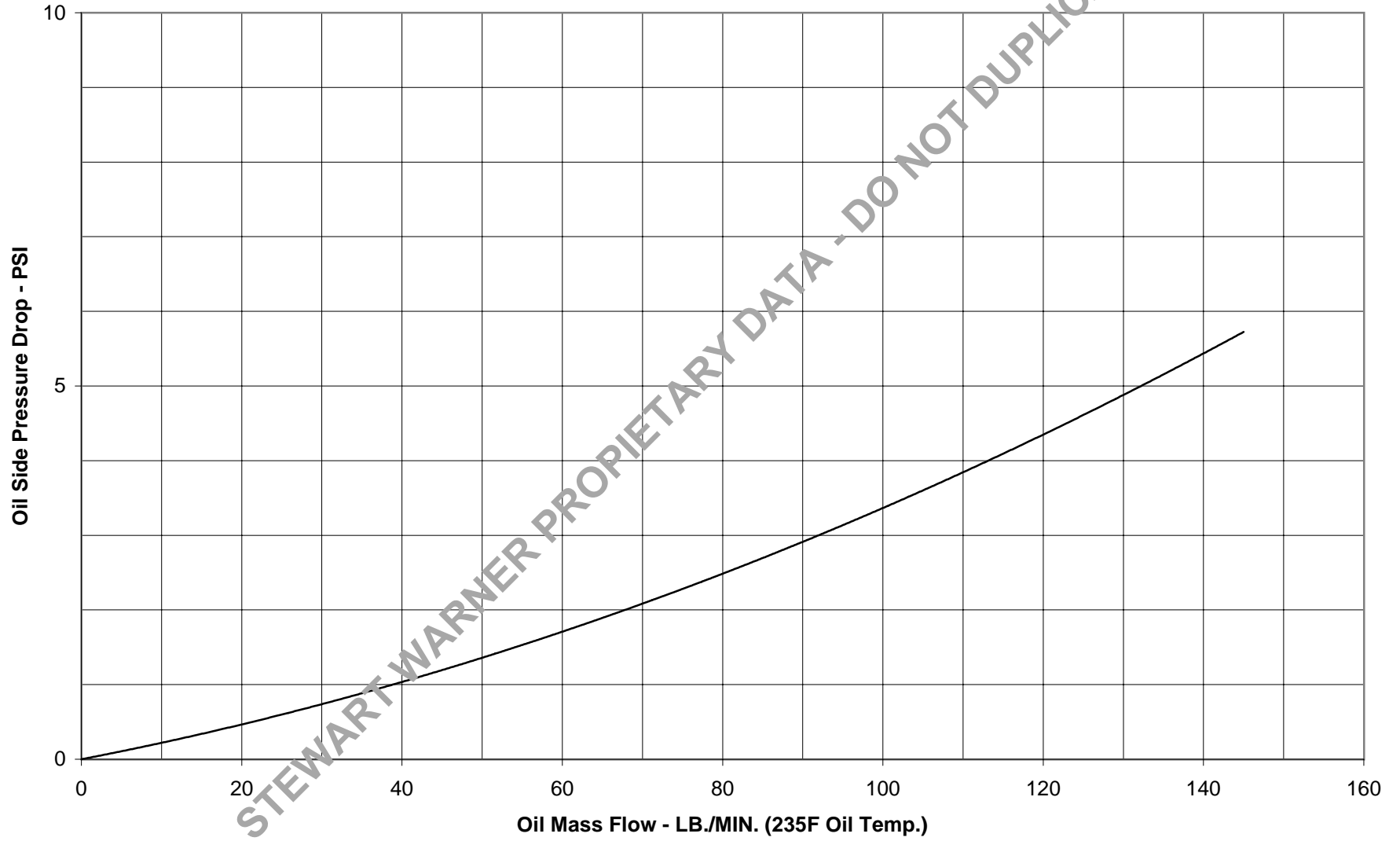

8 7 6 5 4 3 2 1

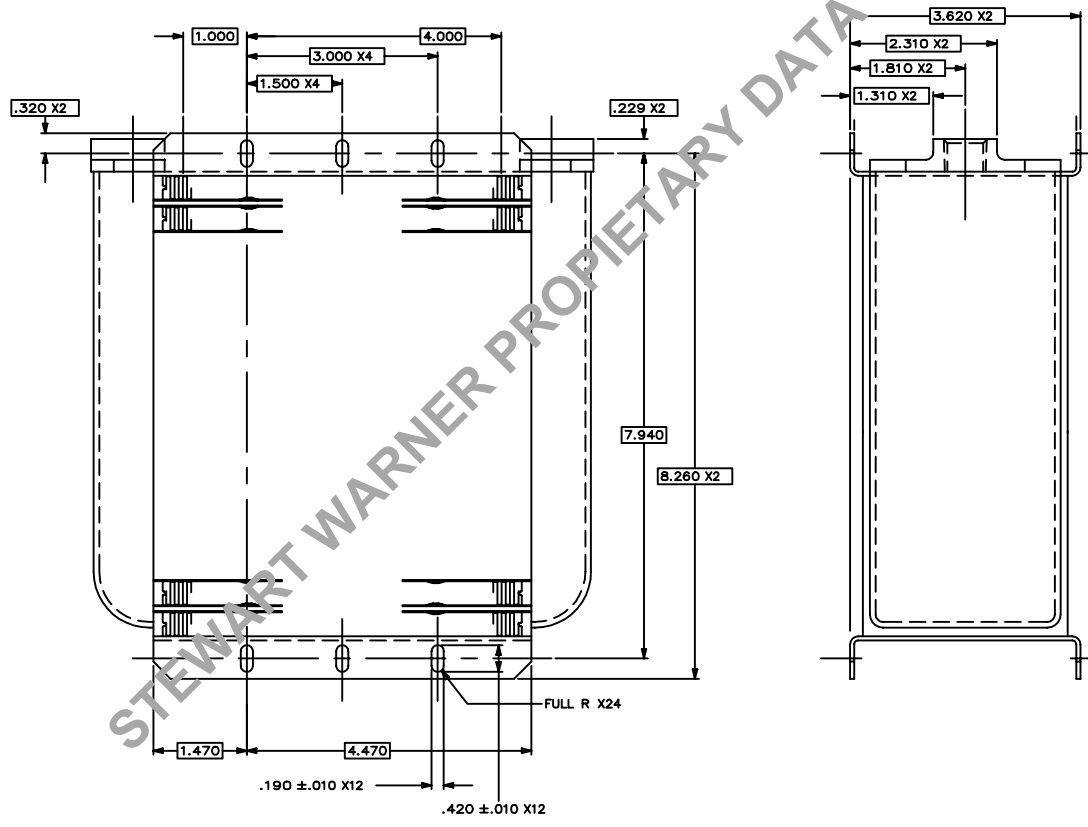
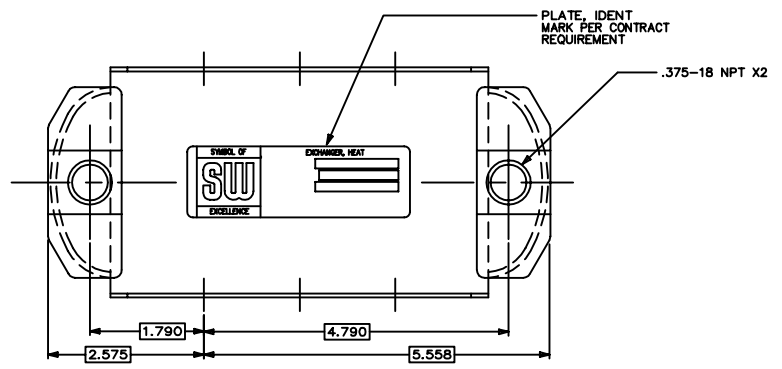

		REVISIONS		
ZONE	REV	DESCRIPTION	DATE	APPROVED
		THIS DRAWING HAS BEEN GENERATED AND IS MAINTAINED BY A CAD SYSTEM. CHANGES SHALL ONLY BE INCORPORATED AS DIRECTED BY THE DESIGN ACTIVITY.		

10614T

STEWART WARNER SOUTH WIND CORPORATION
INDIANAPOLIS, INDIANA

TITLE
OIL COOLER

SIZE D	CAGE NO. 78385	DWG NO. 10614T
SCALE	WT	SHEET

THIS DRAWING IS PREPARED IN ACCORDANCE WITH:
ASME Y14.5-2009 ENGINEERING DRAWING PRACTICES AND
ASME Y14.5-2009 DIMENSIONING AND TOLERANCING FOR
ENGINEERING DRAWINGS.

THE INFORMATION DISCLOSED HEREIN CONTAINS PROPRIETARY
DATA OF STEWART-WARNER CORPORATION. NEITHER THE DOC-
UMENT NOR THE INFORMATION DISCLOSED HEREIN SHALL BE
REPRODUCED OR TRANSMITTED TO OTHER PERSONS OR USED
FOR MANUFACTURING PURPOSES OR DISCLOSED TO OTHERS
FOR ANY PURPOSE EXCEPT AS SPECIFICALLY AUTHORIZED IN
WRITING BY STEWART-WARNER CORPORATION.

8 7 6 5 4 3 2 1

Stewart Warner 10614T Calculated Heat Rejection

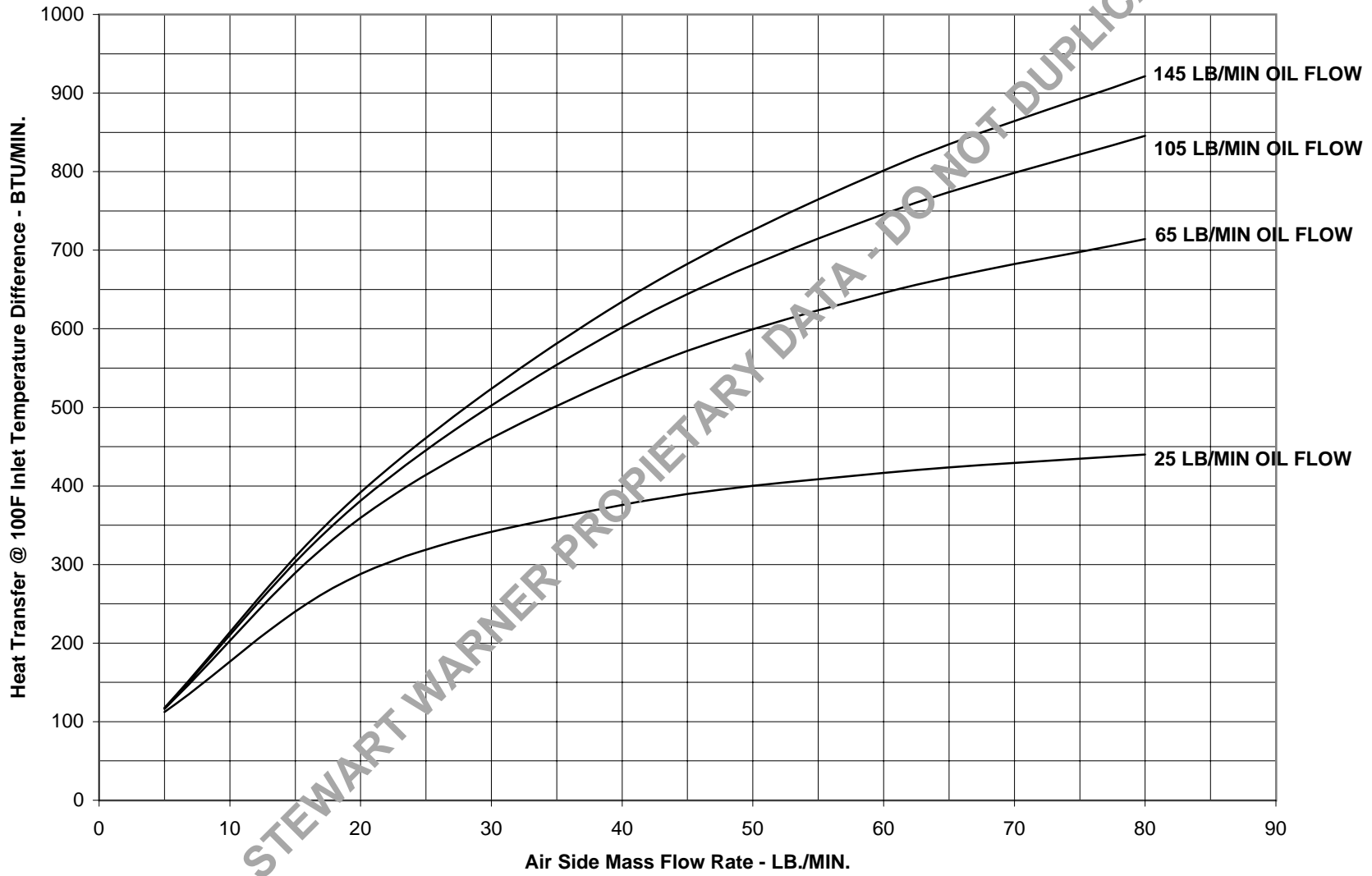

Stewart Warner 10614T Air Side Pressure Drop

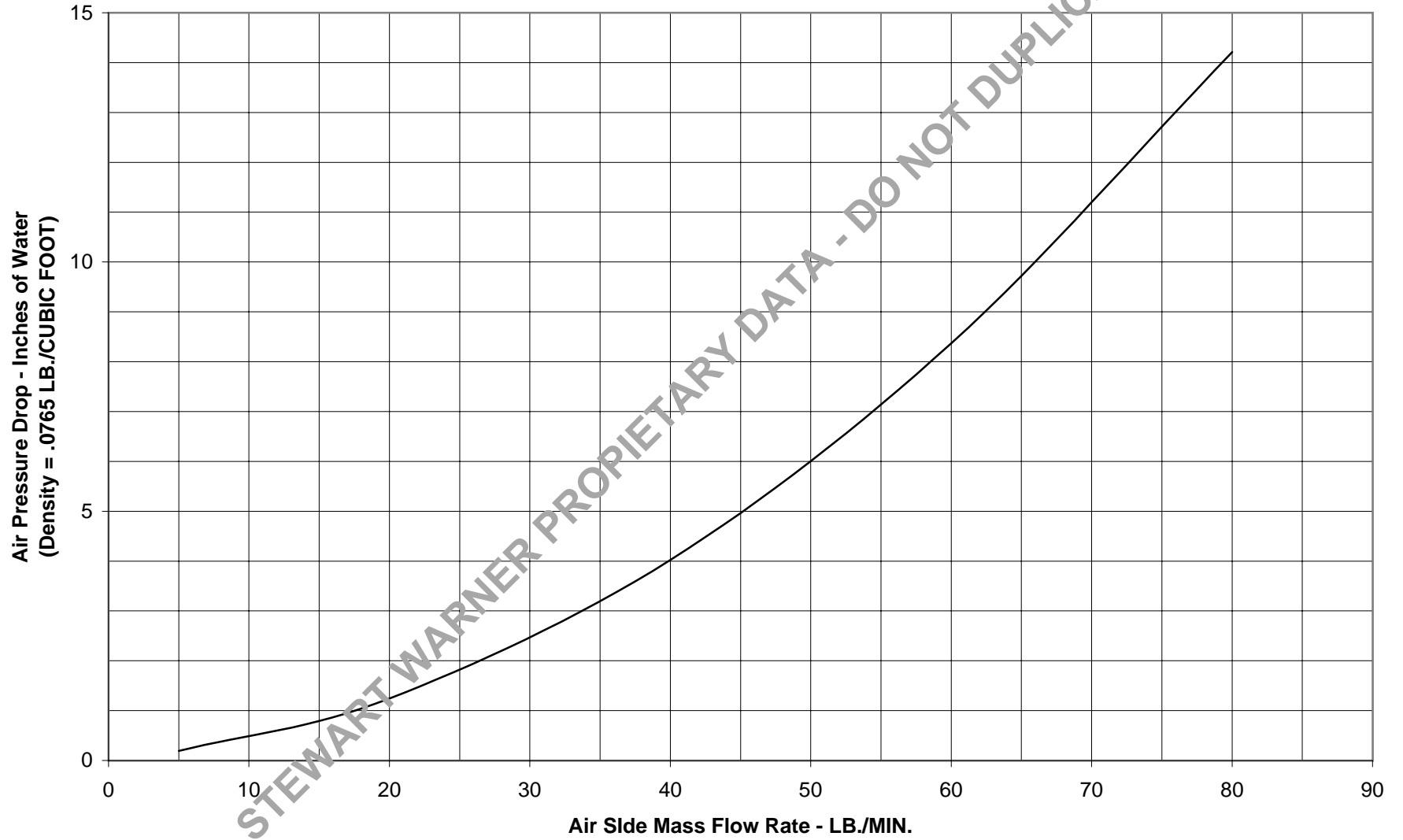

STEWART WARNER PROPRIETARY DATA - DO NOT DUPLICATE

Stewart Warner 10614T Oil Side Pressure Drop

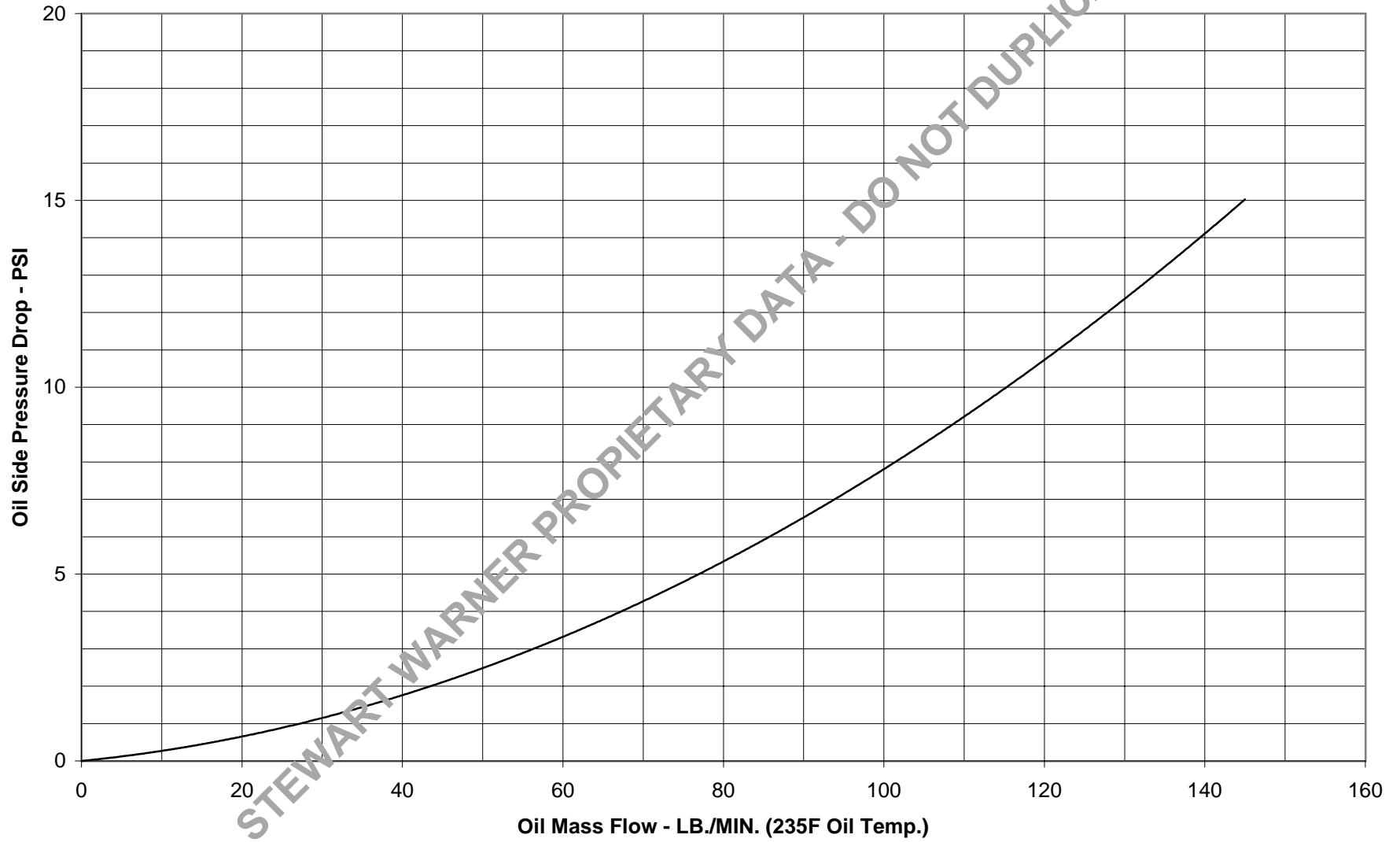

STEWART WARNER PROPRIETARY DATA - DO NOT DUPLICATE

8 7 6 5 4 3 2 1

		REVISIONS			
ZONE	REV	DESCRIPTION	DATE	APPROVED	

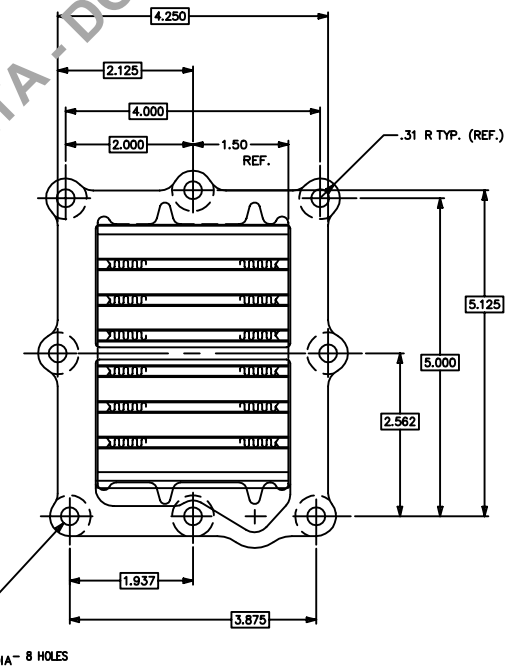
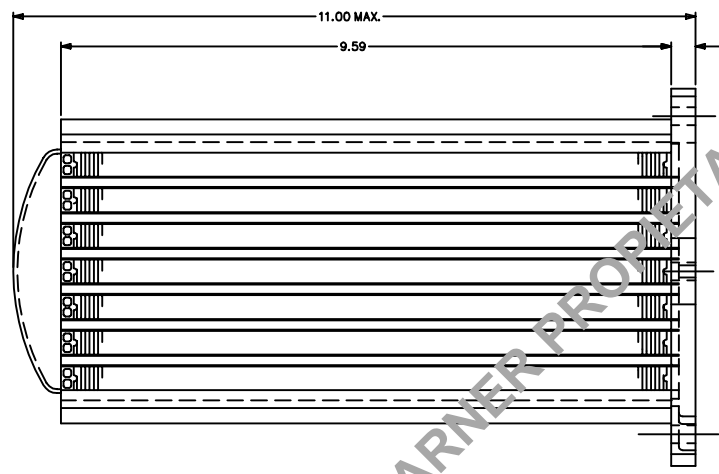
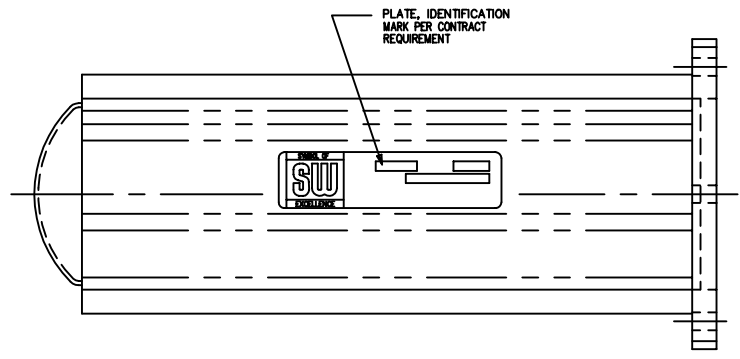

10639B

STEWART WARNER PROPRIETARY DATA - DO NOT DUPLICATE

THIS DRAWING IS PREPARED IN ACCORDANCE WITH
 ASME Y14.5-2009 ENGINEERING DRAWING PRACTICES AND
 ASME Y14.5-2009 DIMENSIONING AND TOLERANCING FOR
 ENGINEERING DRAWINGS.

THE INFORMATION DISCLOSED HEREIN CONTAINS PROPRIETARY
 DATA OF STEWART-WARNER CORPORATION. NEITHER THIS DOC-
 UMENT NOR THE INFORMATION DISCLOSED HEREIN SHALL BE
 REPRODUCED OR TRANSMITTED IN ANY FORM OR BY ANY
 MEANS, ELECTRONIC OR MECHANICAL, INCLUDING PHOTOCOPY-
 ING, RECORDING, OR BY ANY INFORMATION STORAGE AND
 RETRIEVAL SYSTEM, WITHOUT PERMISSION IN WRITING BY
 STEWART-WARNER CORPORATION.

STEWART WARNER SOUTH WIND CORPORATION INDIANAPOLIS, INDIANA		
TITLE OIL COOLER		
SIZE D	CAGE NO. 78385	DWG NO. 10639B
SCALE	WT	SHEET

D
C
B
A

D
C
B
A

FORM NO. 1453 REV. 12-99 8 7 6 5 4 3 2 1

Stewart Warner 10639B Calculated Heat Rejection

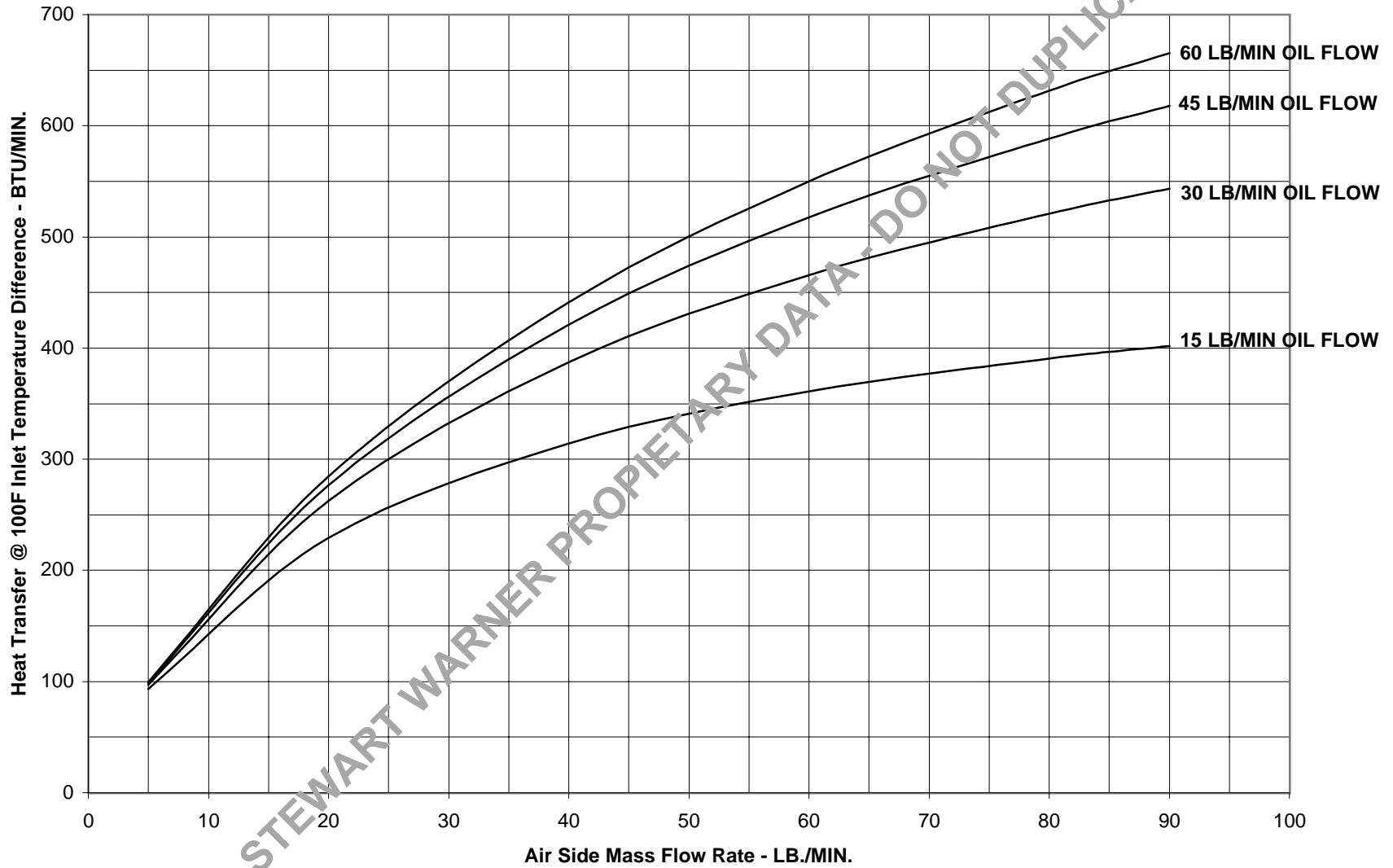

Stewart Warner 10639B Air Side Pressure Drop

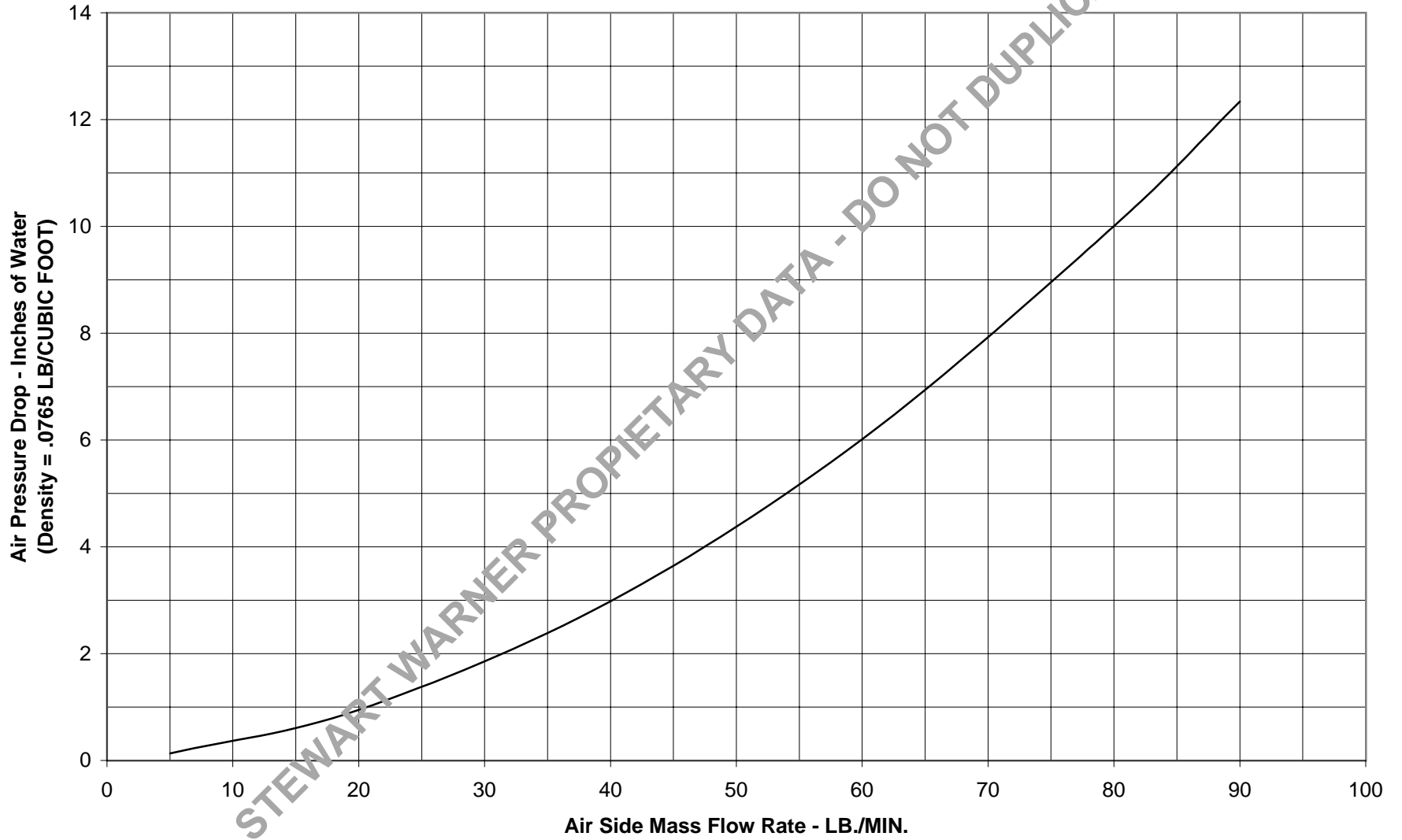

STEWART WARNER PROPRIETARY DATA - DO NOT DUPLICATE

Stewart Warner 10639B Oil Side Pressure Drop

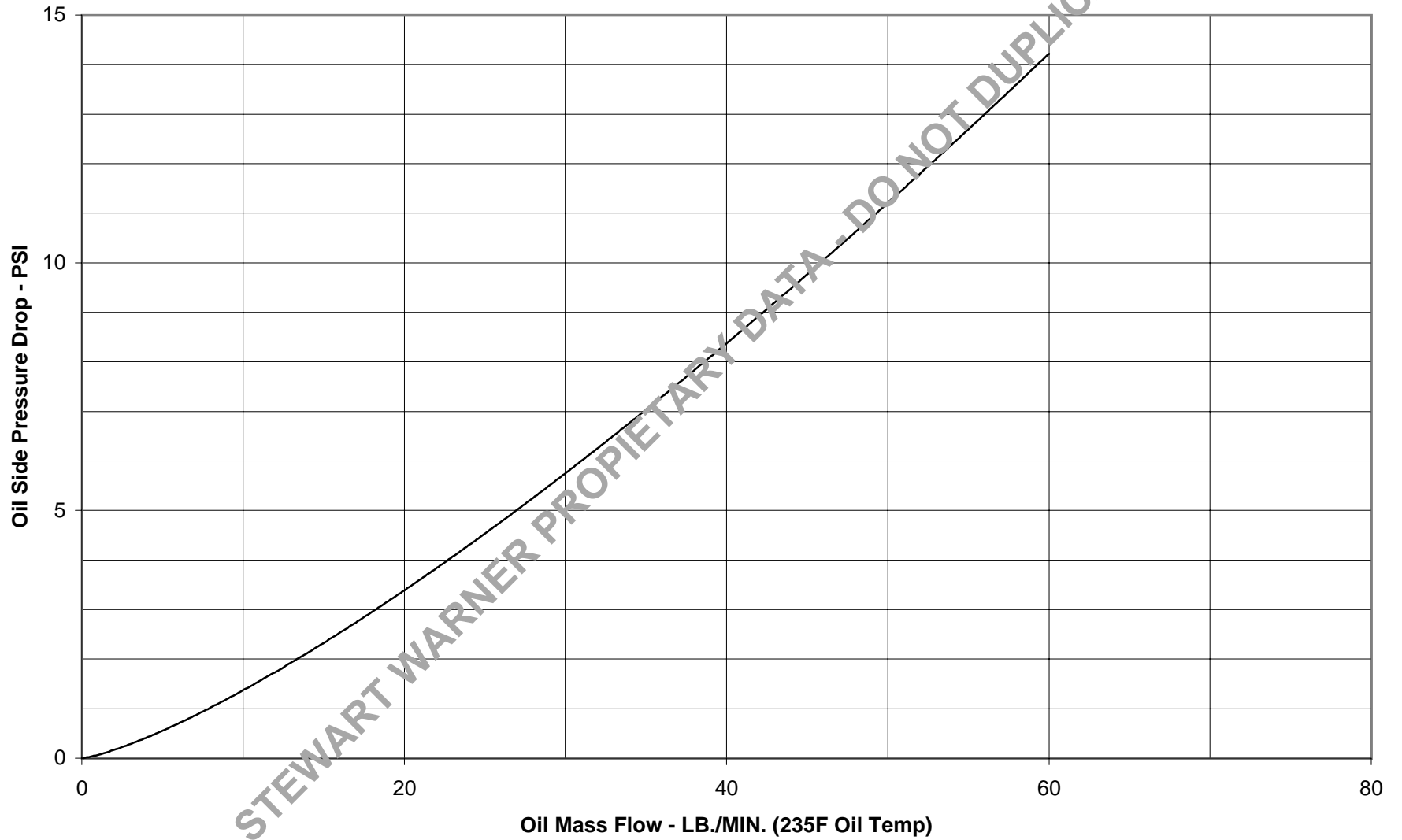

STEWART WARNER PROPRIETARY DATA - DO NOT DUPLICATE

REV		DESCRIPTION	DATE	APPROVED

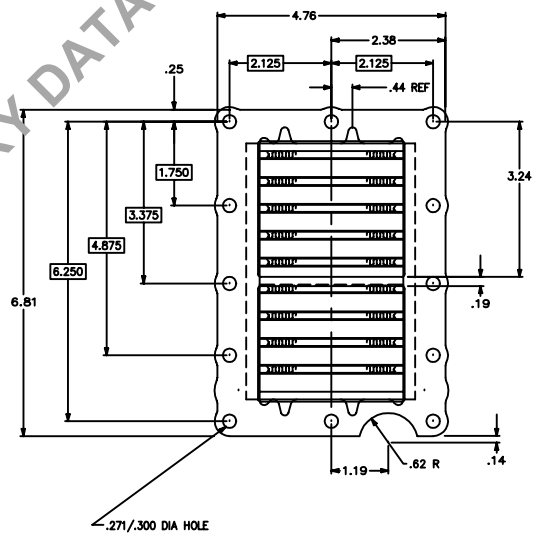
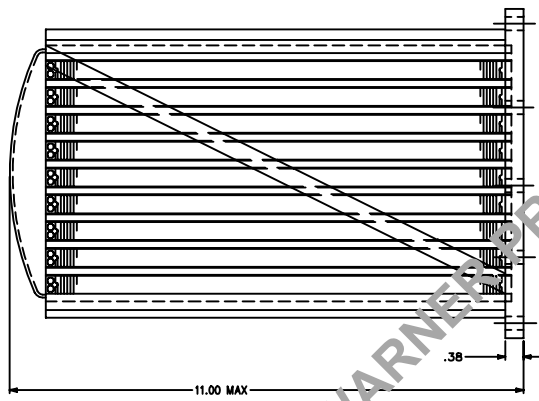
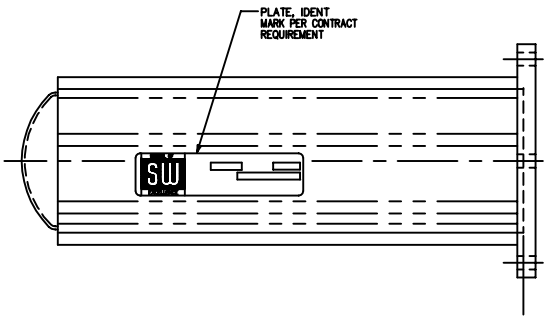

STEWART WARNER PROPRIETARY DATA - DO NOT DUPLICATE

10721A

THIS DRAWING IS PREPARED IN ACCORDANCE WITH THE SPECIFICATIONS AND REQUIREMENTS OF THE CUSTOMER AND IS NOT TO BE USED FOR ANY OTHER PURPOSE WITHOUT THE WRITTEN PERMISSION OF STEWART WARNER CORPORATION.

THE OPERATOR SHALL BE RESPONSIBLE FOR THE PROPER INSTALLATION AND MAINTENANCE OF THIS EQUIPMENT. STEWART WARNER CORPORATION SHALL NOT BE RESPONSIBLE FOR ANY DAMAGE TO OR LOSS OF EQUIPMENT OR PERSONAL INJURY OR DEATH RESULTING FROM THE USE OF THIS EQUIPMENT.

STEWART WARNER SOUTH WIND CORPORATION MICHIGANVILLE, OHIO			
TITLE OIL COOLER			
SIZE E	CAGE NO. 78385	REV NO. 10721A	
SCALE	WT		SHEET

Stewart Warner 10721A Calculated Heat Rejection

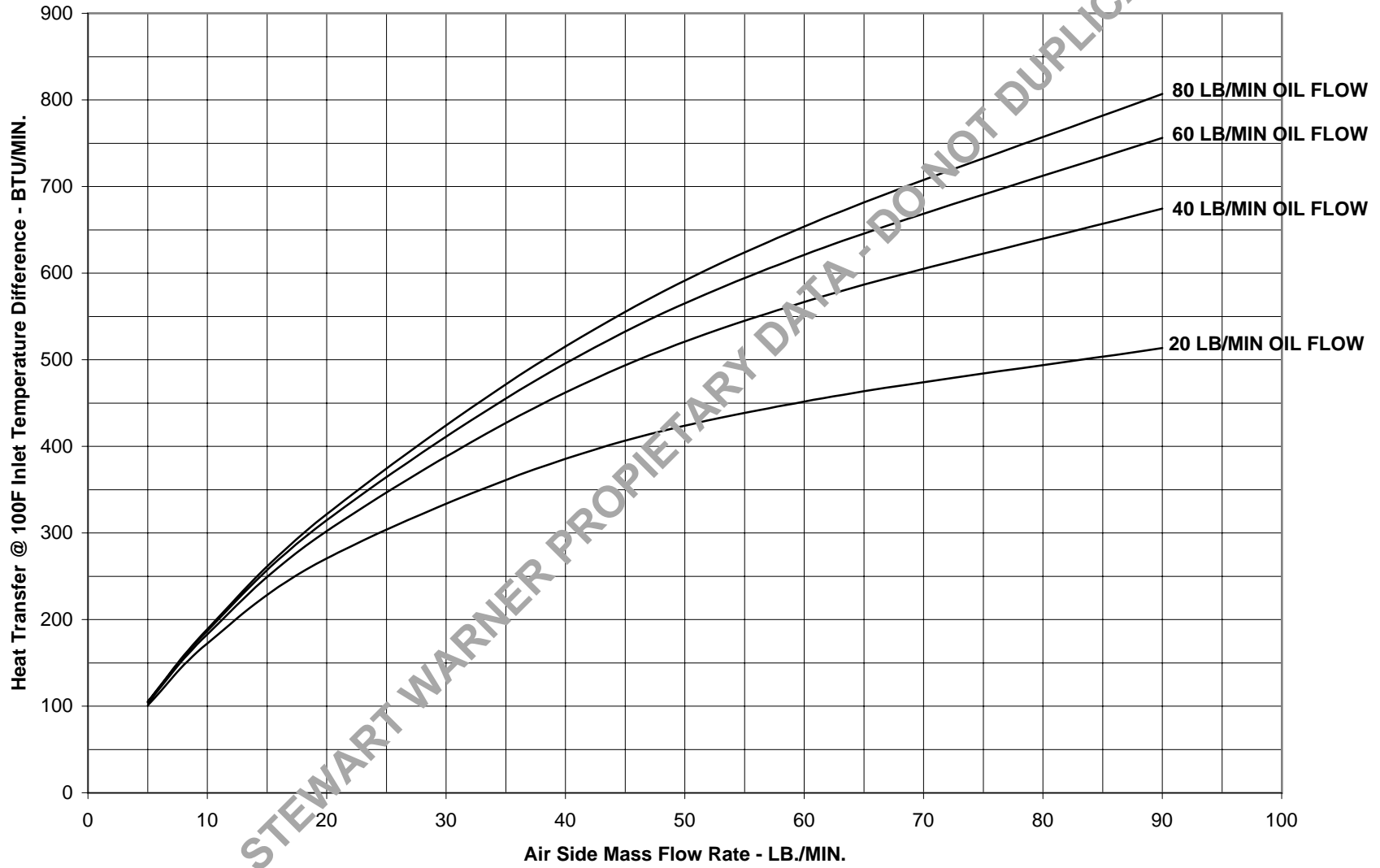

Stewart Warner 10721A Air Side Pressure Drop

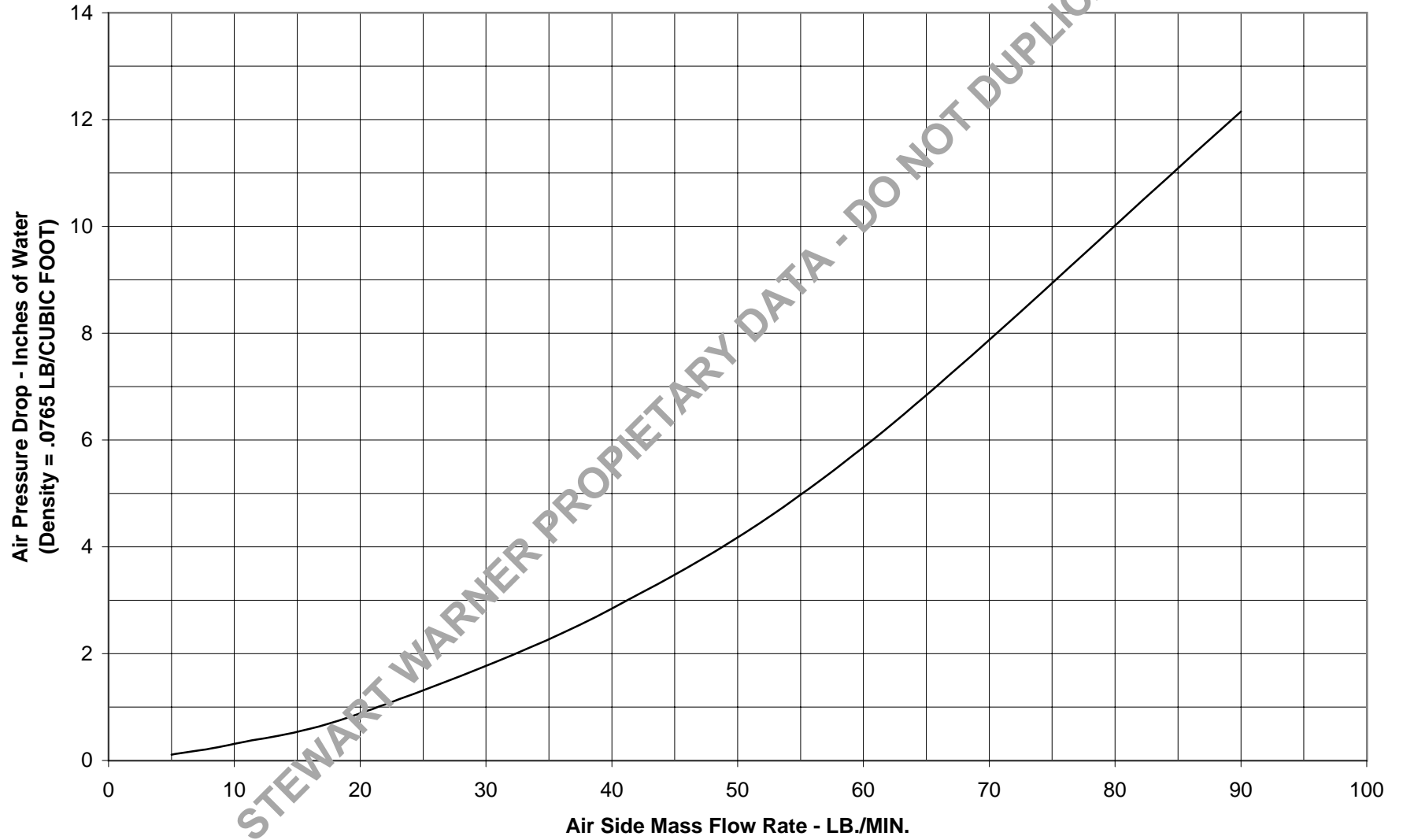

STEWART WARNER PROPRIETARY DATA - DO NOT DUPLICATE

Stewart Warner 10721A Oil Side Pressure Drop

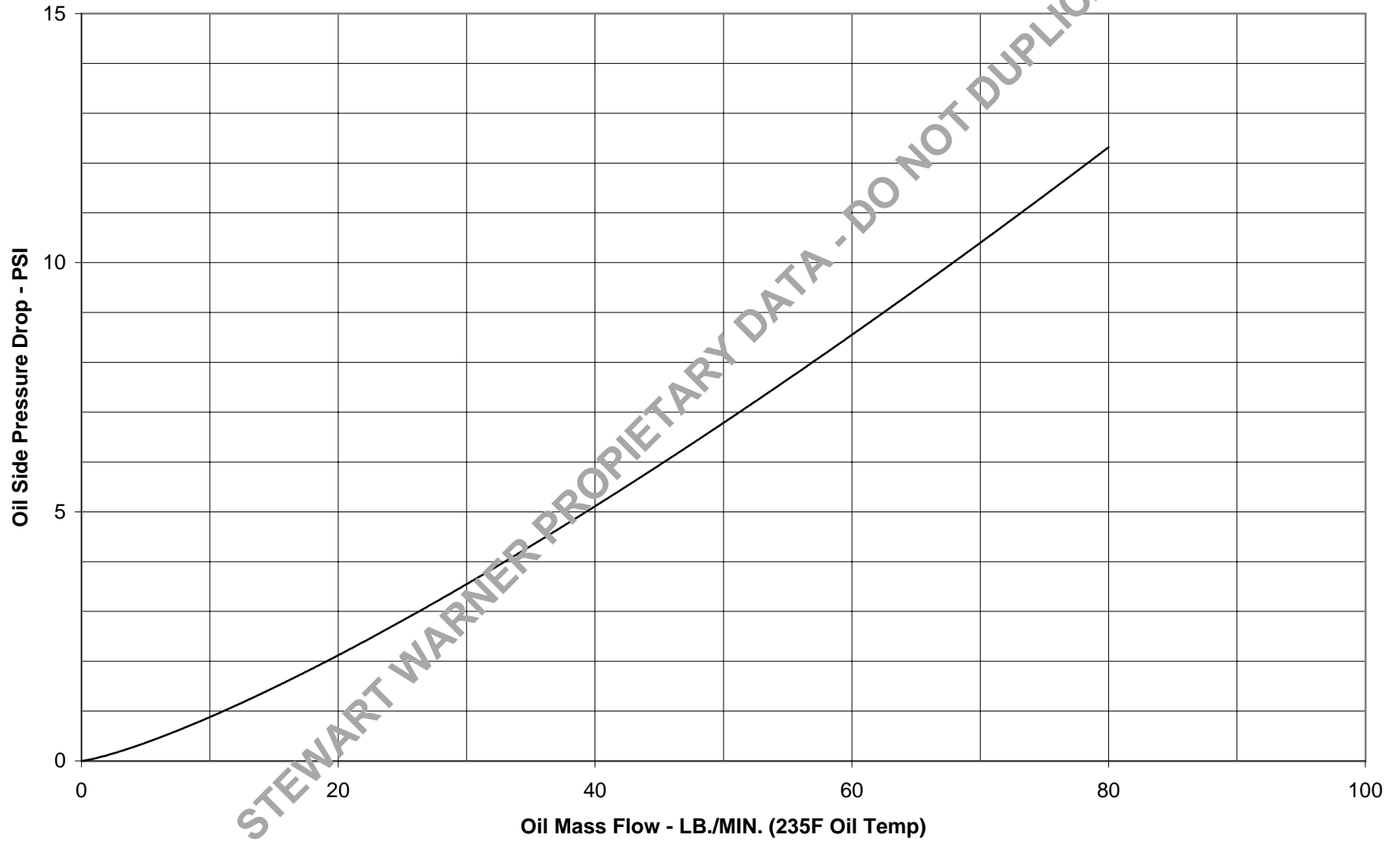

STEWART WARNER PROPRIETARY DATA - DO NOT DUPLICATE

8 | 7 | 6 | 5 | 4 | 3 | 2 | 1

		REVISIONS			
ZONE	REV	DESCRIPTION	DATE	APPROVED	

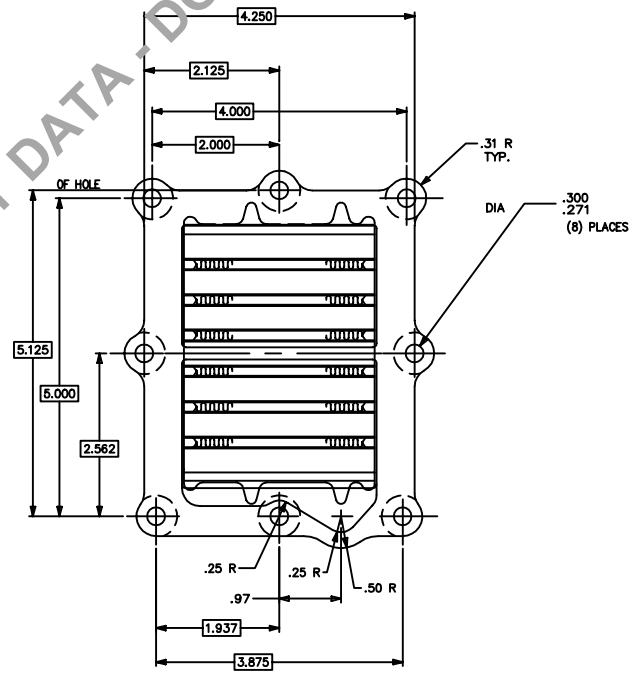
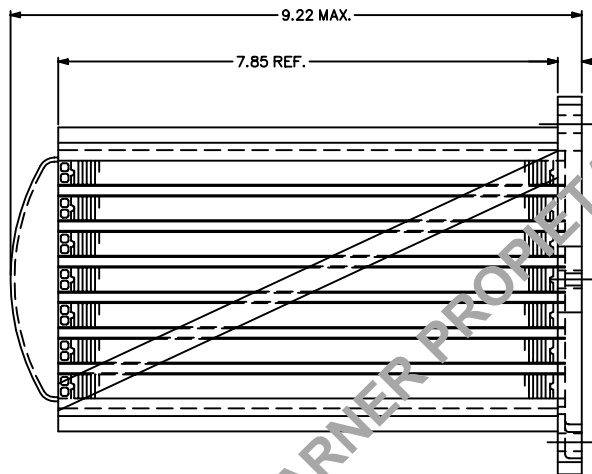
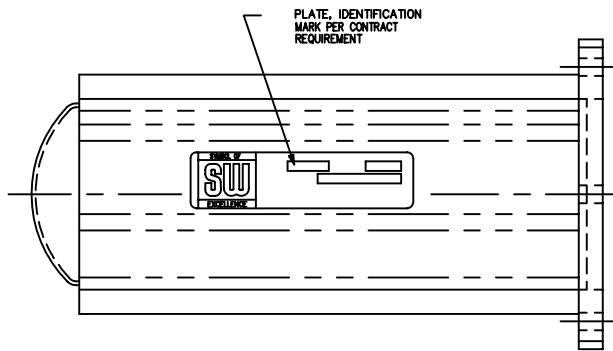

10722A

STEWART WARNER PROPRIETARY DATA - DO NOT DUPLICATE

THIS DRAWING IS PREPARED IN ACCORDANCE WITH:
 ASME Y14.5-2009 DIMENSIONING PRACTICES AND TOLERANCING FOR ENGINEERING DRAWINGS.

THE INFORMATION DISCLOSED HEREIN CONTAINS PROPRIETARY DATA OF STEWART-WARNER CORPORATION. NEITHER THIS DOCUMENT NOR THE INFORMATION DISCLOSED HEREIN SHALL BE REPRODUCED OR TRANSMITTED IN ANY FORM OR BY ANY MEANS, ELECTRONIC OR MECHANICAL, INCLUDING PHOTOCOPYING, RECORDING, OR BY ANY INFORMATION STORAGE AND RETRIEVAL SYSTEM, WITHOUT THE WRITTEN PERMISSION OF STEWART-WARNER CORPORATION.

STEWART WARNER SOUTH WIND CORPORATION INDIANAPOLIS, INDIANA		
TITLE OIL COOLER		
SIZE D	CAGE NO. 78385	DWG NO. 10722A
SCALE	WT	SHEET

8 | 7 | 6 | 5 | 4 | 3 | 2 | 1

Stewart Warner 10722A Calculated Heat Rejection

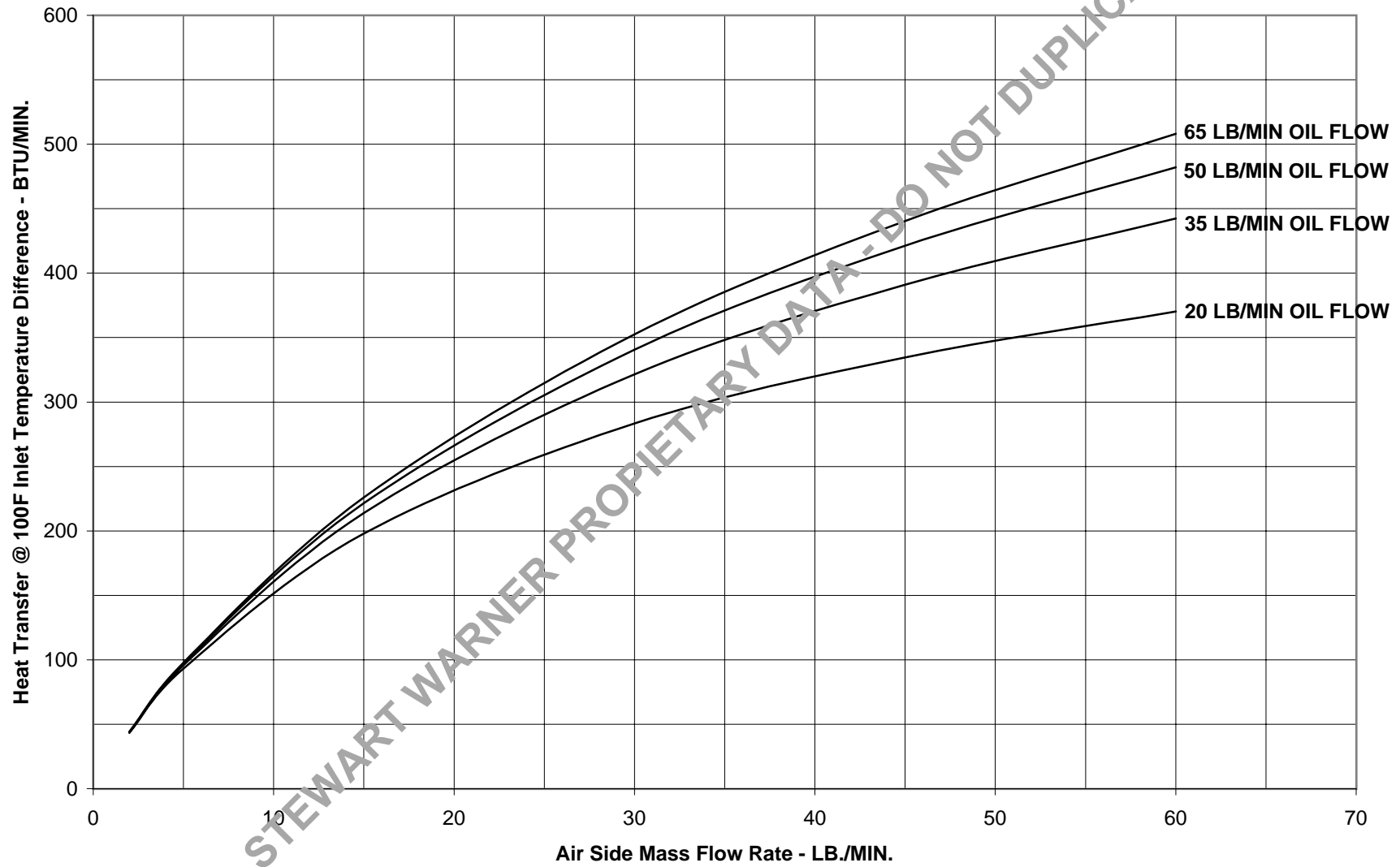

Stewart Warner 10722A Air Side Pressure Drop

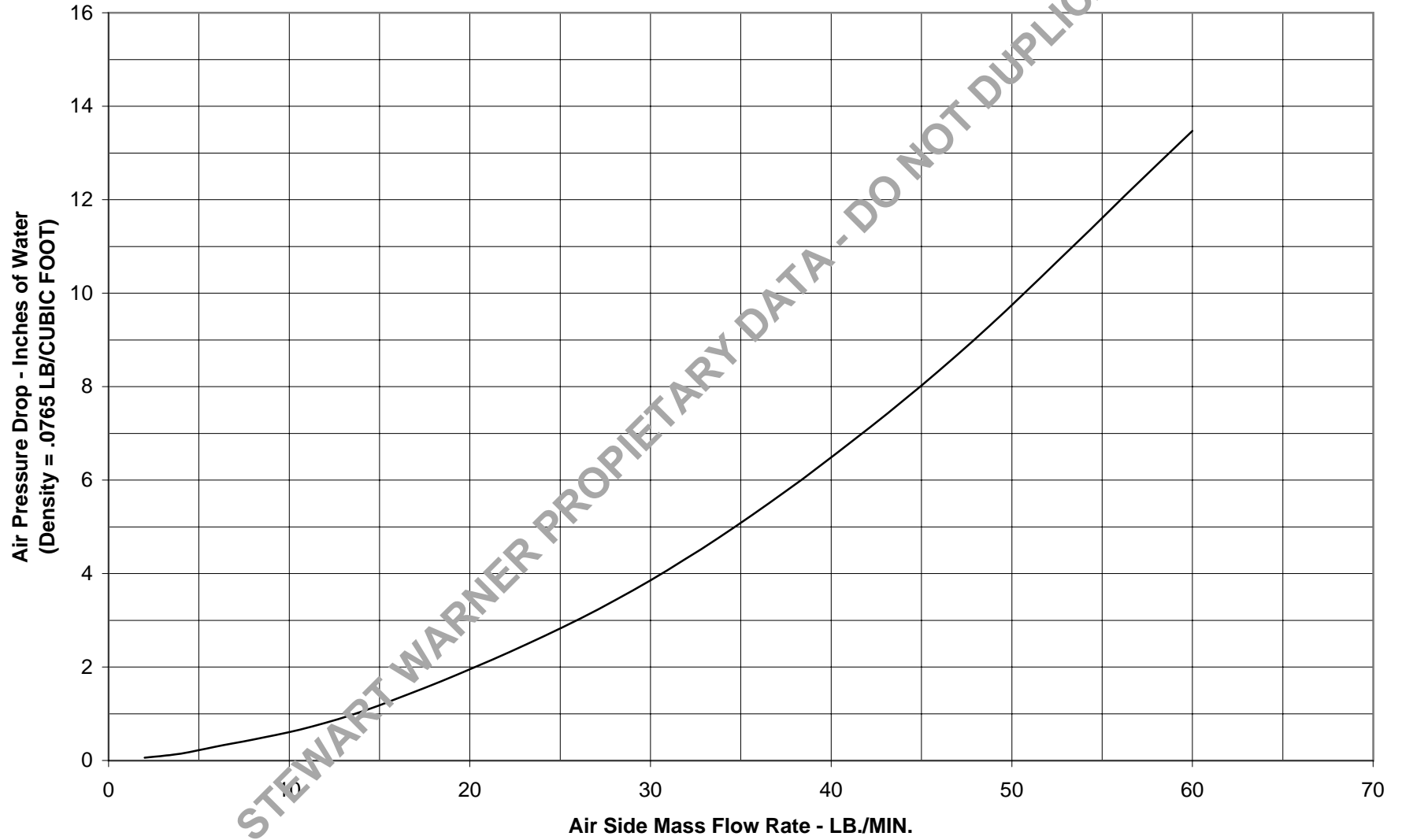

STEWART WARNER PROPRIETARY DATA - DO NOT DUPLICATE

Stewart Warner 10722A Oil Side Pressure Drop

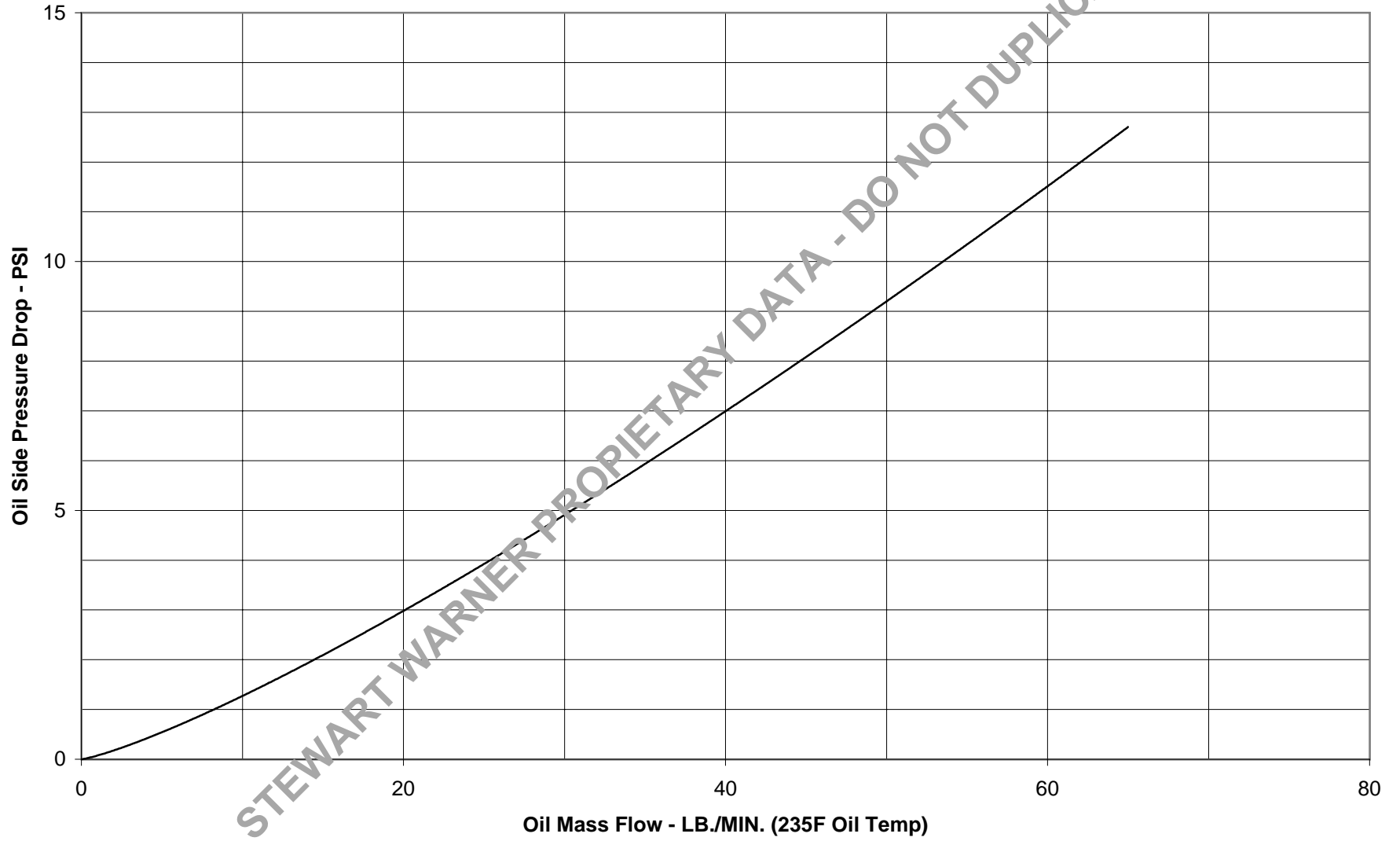

8 7 6 5 4 3 2 1

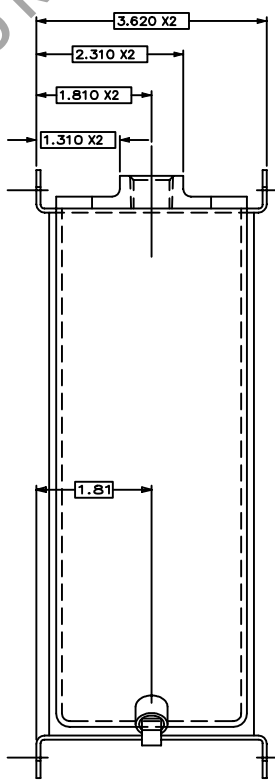
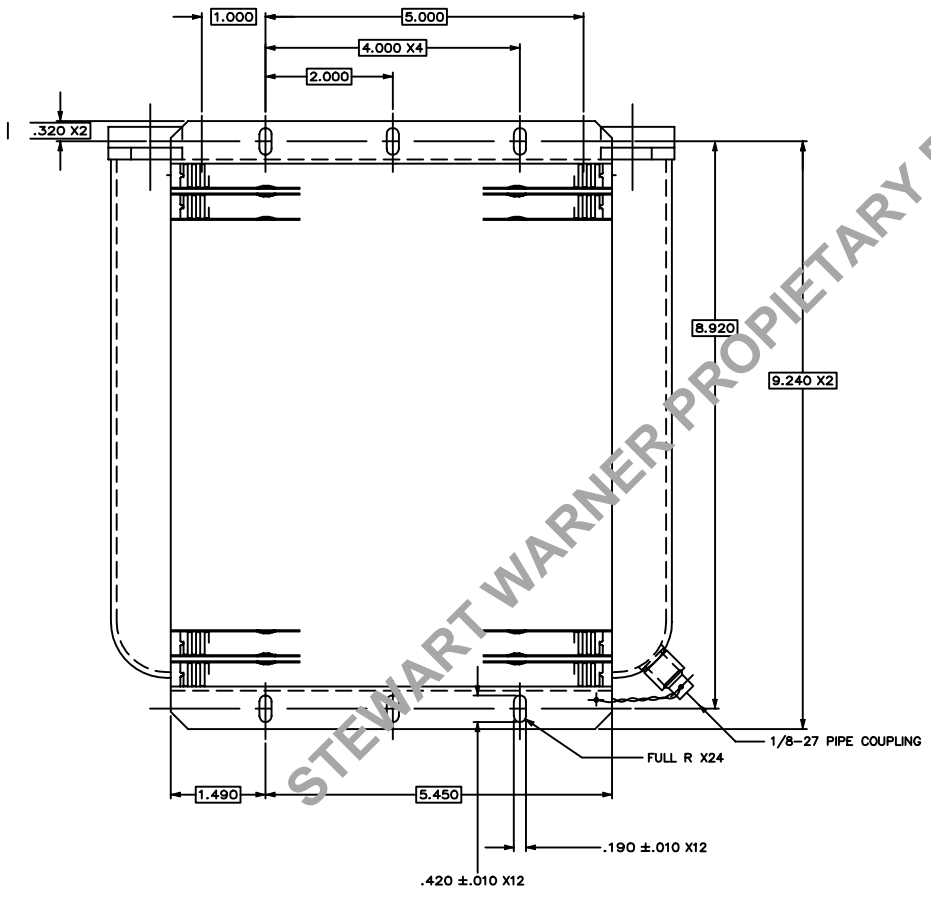
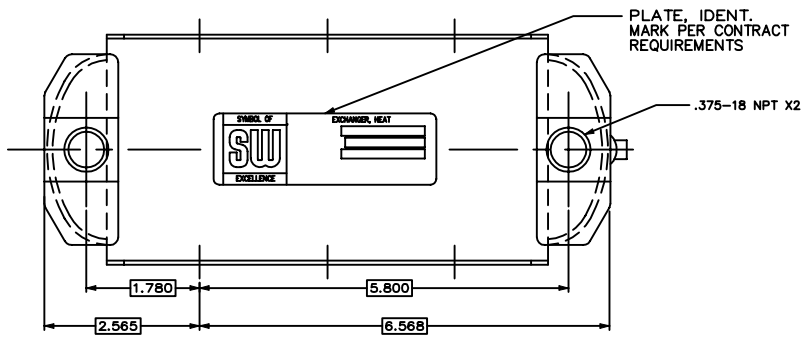

		REVISIONS			
ZONE	REV	DESCRIPTION	DATE	APPROVED	

STEWART WARNER PROPRIETARY DATA - DO NOT DUPLICATE

10865B

THIS DRAWING IS PREPARED IN ACCORDANCE WITH:
 DDG-STD-100 ENGINEERING DRAWING PRACTICES AND
 ASD-STD-100 ENGINEERING AND TOPOGRAPHY FOR
 ENGINEERING DRAWINGS.

THE INFORMATION DISCLOSED HEREIN CONTAINS PROPRIETARY
 DATA OF STEWART-WARNER CORPORATION. HEREBY THE IN-
 FORMATION DISCLOSED HEREIN SHALL BE
 REPRODUCED OR TRANSMITTED TO OTHER DOCUMENTS OR USED
 FOR MANUFACTURING PURPOSES OR DISCLOSED TO OTHERS
 FOR ANY PURPOSE EXCEPT AS SPECIFICALLY AUTHORIZED IN
 WRITING BY STEWART-WARNER CORPORATION.

STEWART WARNER SOUTH WIND CORPORATION INDIANAPOLIS, INDIANA		
TITLE OIL COOLER		
SIZE D	CAGE NO. 78385	DWG NO. 10865B
SCALE	WT	SHEET

8 7 6 5 4 3 2 1

Stewart Warner 10865B Calculated Heat Rejection

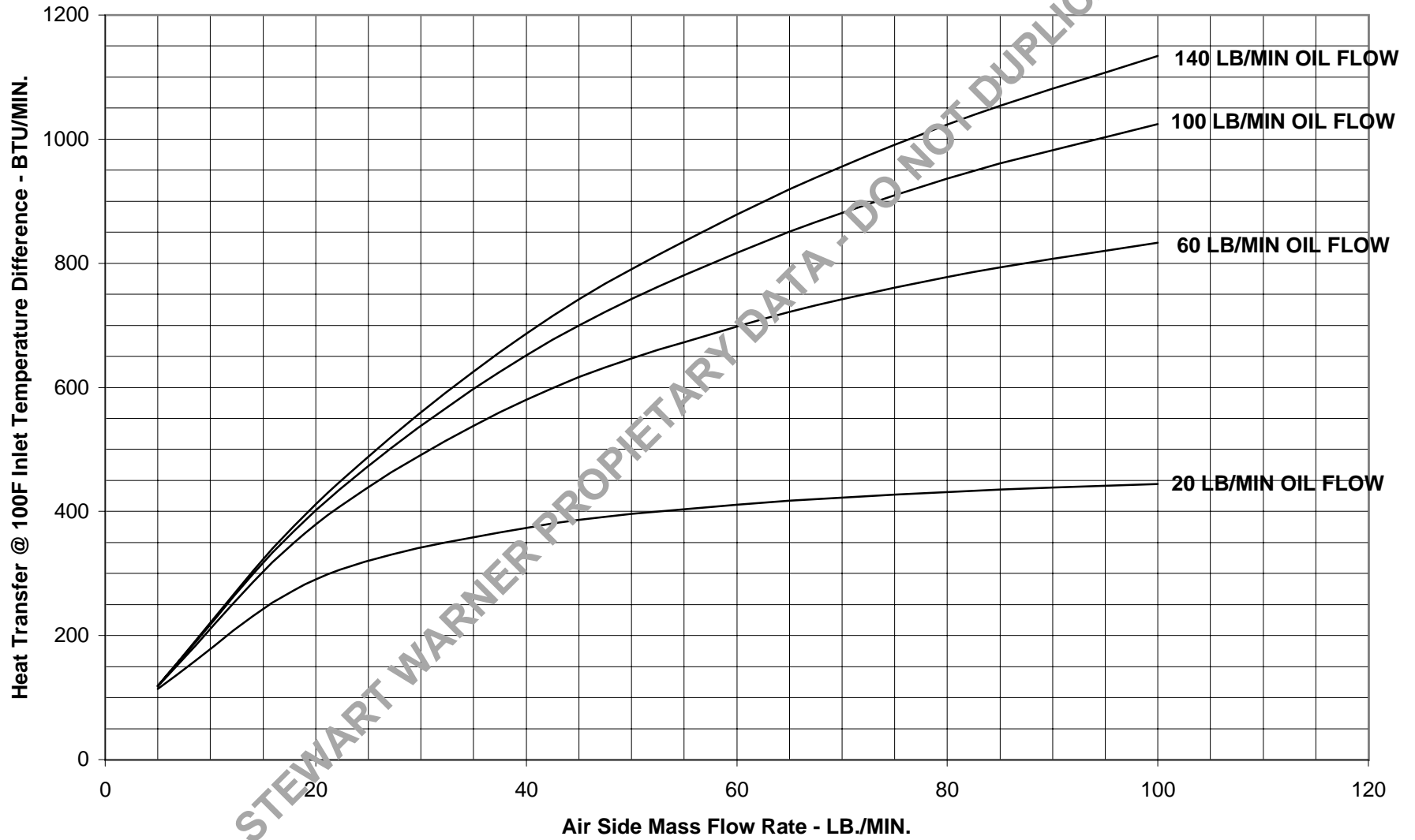

Stewart Warner 10865B Air Side Pressure Drop

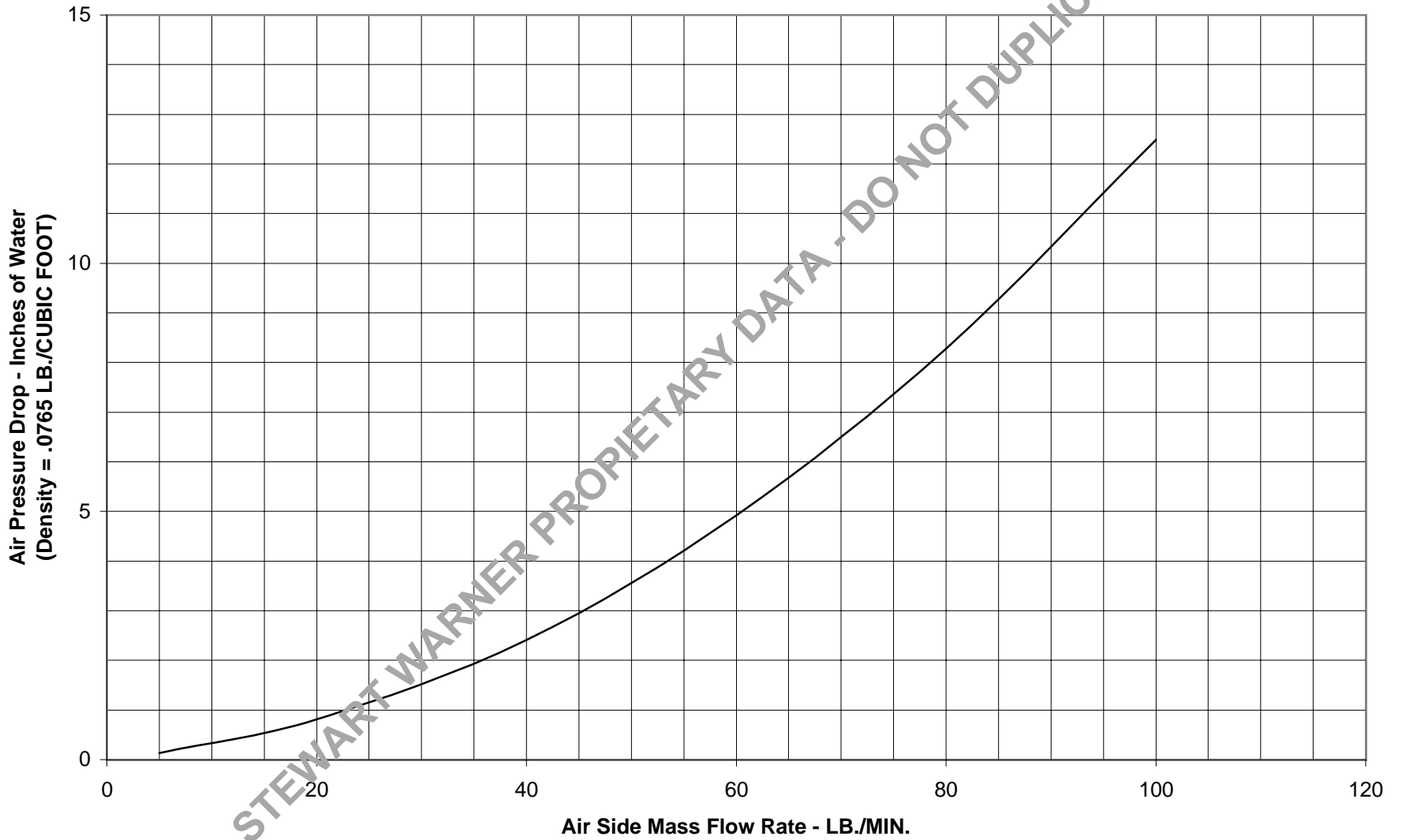

STEWART WARNER PROPRIETARY DATA - DO NOT DUPLICATE

Stewart Warner 10865B Oil Side Pressure Drop

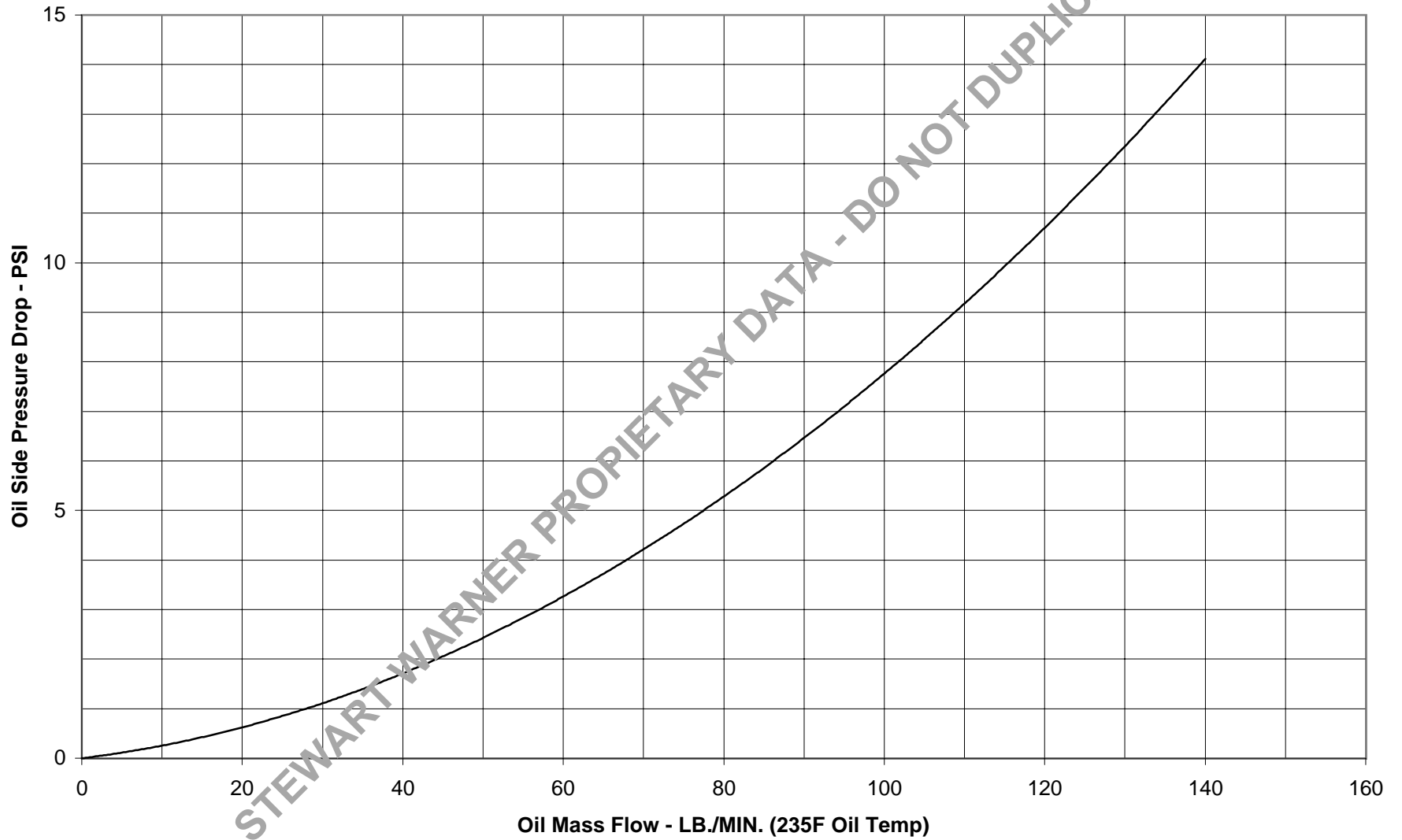

STEWART WARNER PROPRIETARY DATA - DO NOT DUPLICATE

8 7 6 5 4 3 2 1

		REVISIONS		
ZONE	REV	DESCRIPTION	DATE	APPROVED
		THIS DRAWING HAS BEEN GENERATED AND IS MAINTAINED BY A CAD SYSTEM. CHANGES SHALL ONLY BE INCORPORATED AS DIRECTED BY THE DESIGN ACTIVITY.		

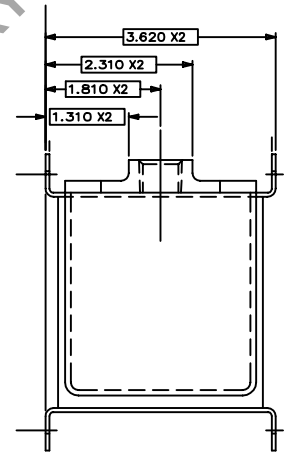
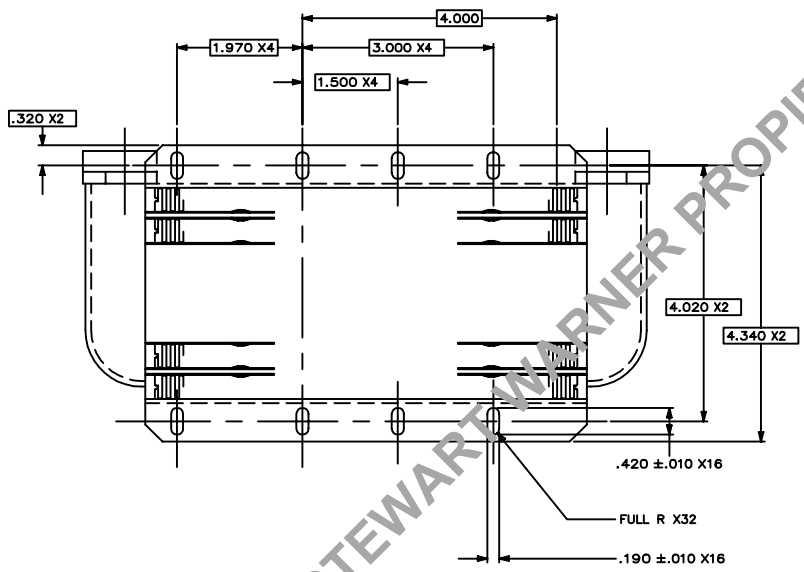
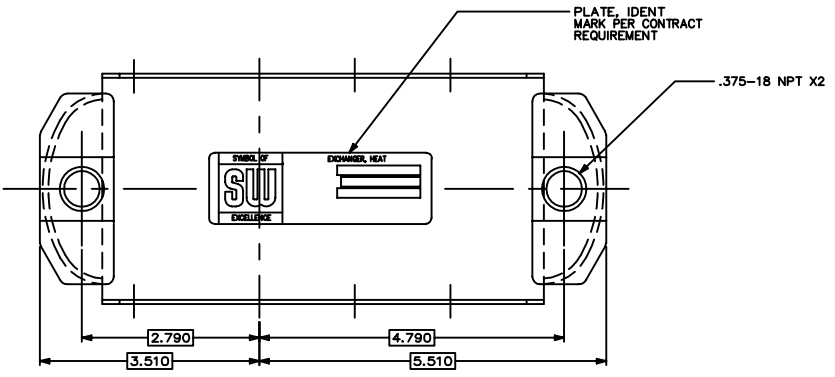

STEWART WARNER PROPRIETARY DATA - DO NOT DUPLICATE

10877A

THIS DRAWING IS PREPARED IN ACCORDANCE WITH ASME Y14.5-2018 ENGINEERING DRAWING PRACTICES AND ASME Y14.5-2018 DIMENSIONING AND TOLERANCING FOR ENGINEERING DRAWINGS.

THE INFORMATION DISCLOSED HEREIN CONTAINS PROPRIETARY DATA OF STEWART-WARNER CORPORATION. THIS DOCUMENT AND THE INFORMATION DISCLOSED HEREIN SHALL BE REPRODUCED OR TRANSMITTED TO OTHER DOCUMENTS OR USED FOR MANUFACTURING PURPOSES OR DISCLOSED TO OTHERS FOR ANY PURPOSE EXCEPT AS SPECIFICALLY AUTHORIZED IN WRITING BY STEWART-WARNER CORPORATION.

STEWART WARNER SOUTH WIND CORPORATION INDIANAPOLIS, INDIANA			
TITLE OIL COOLER			
SIZE D	CAGE NO. 78385	DWG NO. 10877A	
SCALE 1/1		WT	SHEET

FORM NO. 1453 REV. 12-20 8 7 6 5 4 3 2 1

Stewart Warner 10877A Calculated Heat Rejection

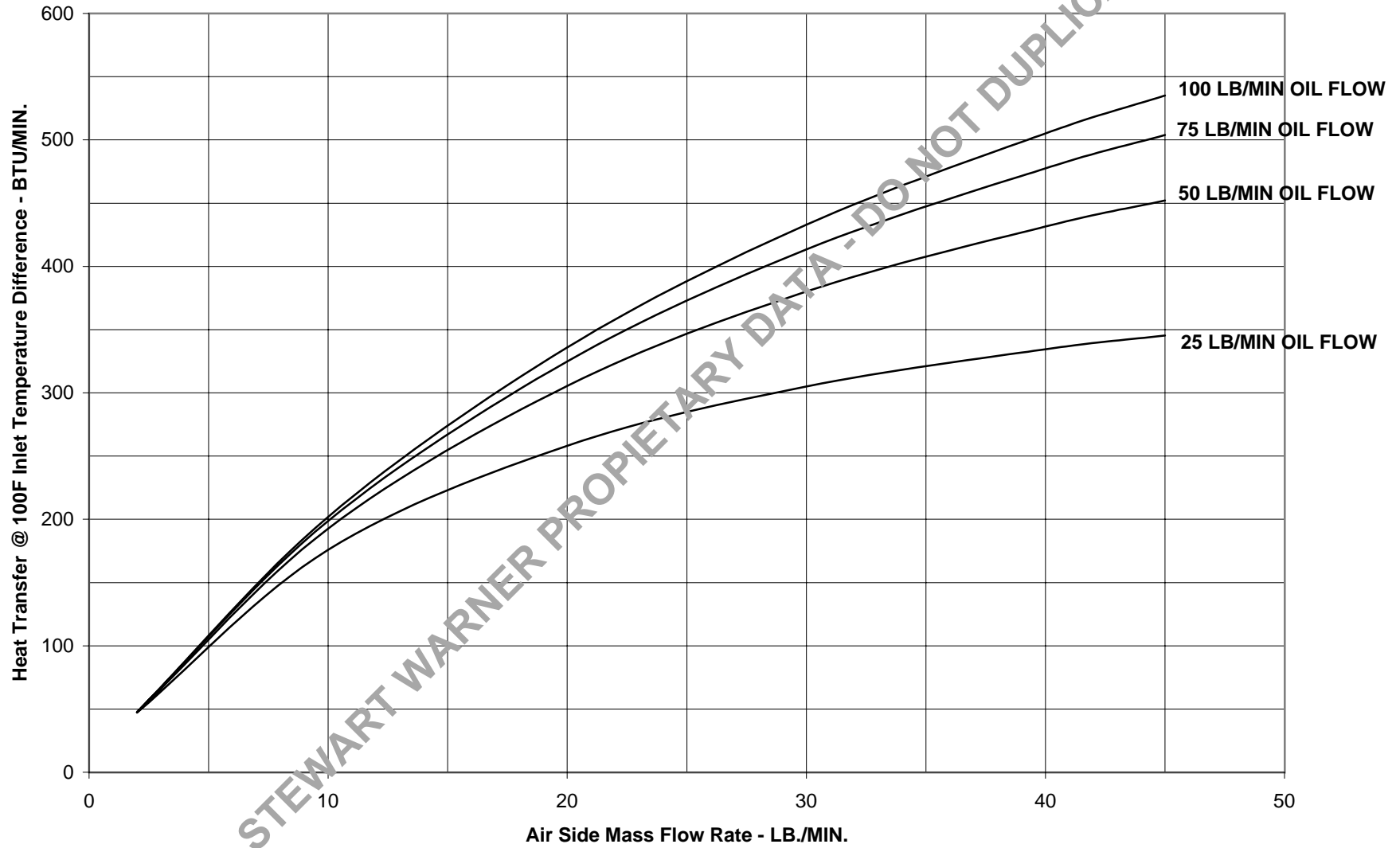

Stewart Warner 10877A Air Side Pressure Drop

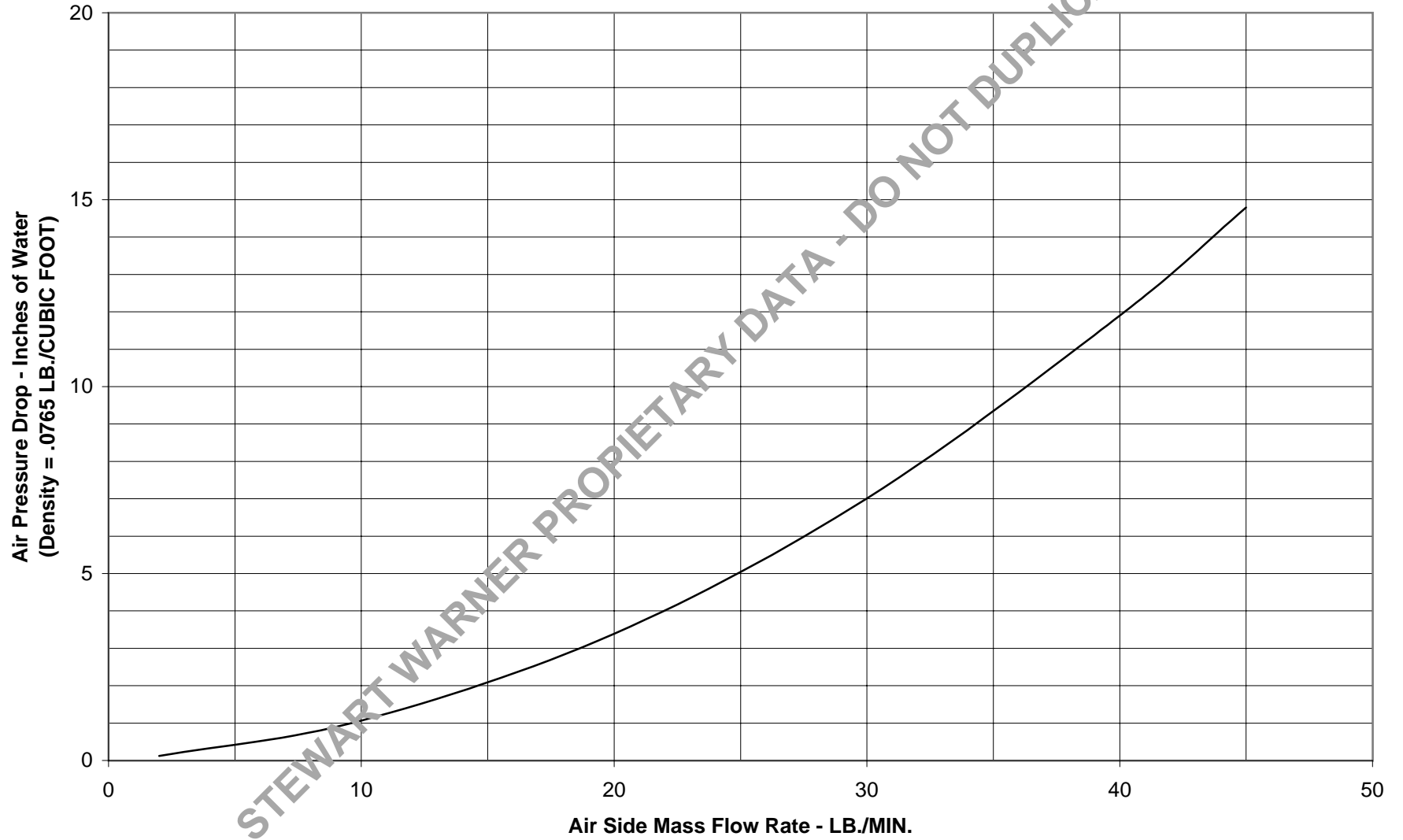

STEWART WARNER PROPRIETARY DATA - DO NOT DUPLICATE

Stewart Warner 10877A Oil Side Pressure Drop

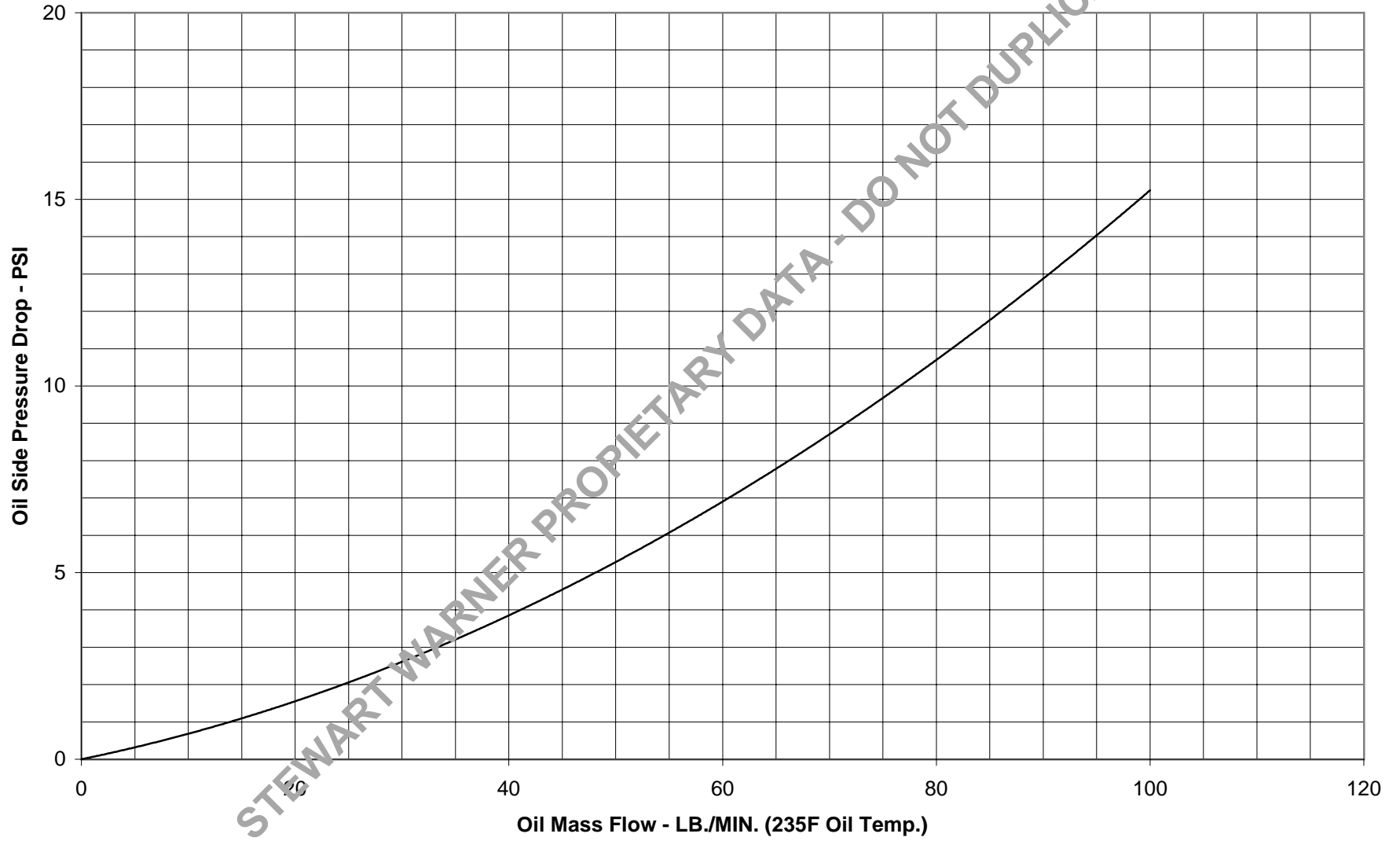

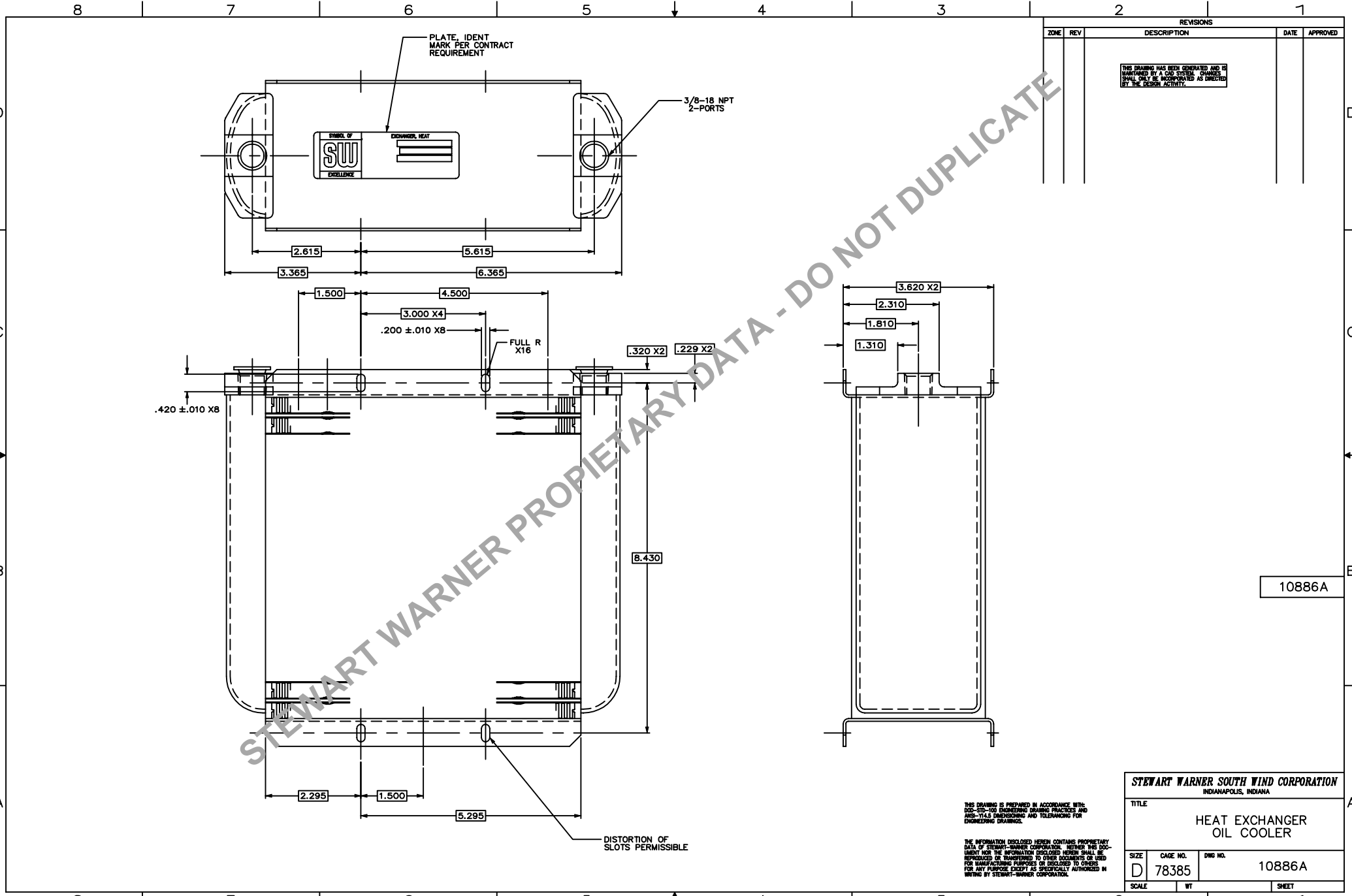

		REVISIONS			
ZONE	REV	DESCRIPTION	DATE	APPROVED	
		THIS DRAWING HAS BEEN GENERATED AND IS MAINTAINED BY A CAD SYSTEM. CHANGES SHALL ONLY BE INCORPORATED AS DIRECTED BY THE DESIGN ACTIVITY.			

10886A

STEWART WARNER SOUTH WIND CORPORATION INDIANAPOLIS, INDIANA		
TITLE HEAT EXCHANGER OIL COOLER		
SIZE D	CAGE NO. 78385	DWG NO. 10886A
SCALE	WT	SHEET

THIS DRAWING IS PREPARED IN ACCORDANCE WITH ASME Y14.5-2009 ENGINEERING DRAWING PRACTICES AND ASME Y14.5-2009 DIMENSIONING AND TOLERANCING FOR ENGINEERING DRAWINGS.

THE INFORMATION DISCLOSED HEREIN CONTAINS PROPRIETARY DATA OF STEWART-WARNER CORPORATION. REUSE OF THIS DOCUMENT WITH THE INFORMATION DISCLOSED HEREIN SHALL BE PROHIBITED OR TRANSFERRED TO OTHER DOCUMENTS OR USED FOR MANUFACTURING PURPOSES OR DISCLOSED TO OTHERS FOR ANY PURPOSE EXCEPT AS SPECIFICALLY AUTHORIZED IN WRITING BY STEWART-WARNER CORPORATION.

Stewart Warner 10886A Calculated Heat Rejection

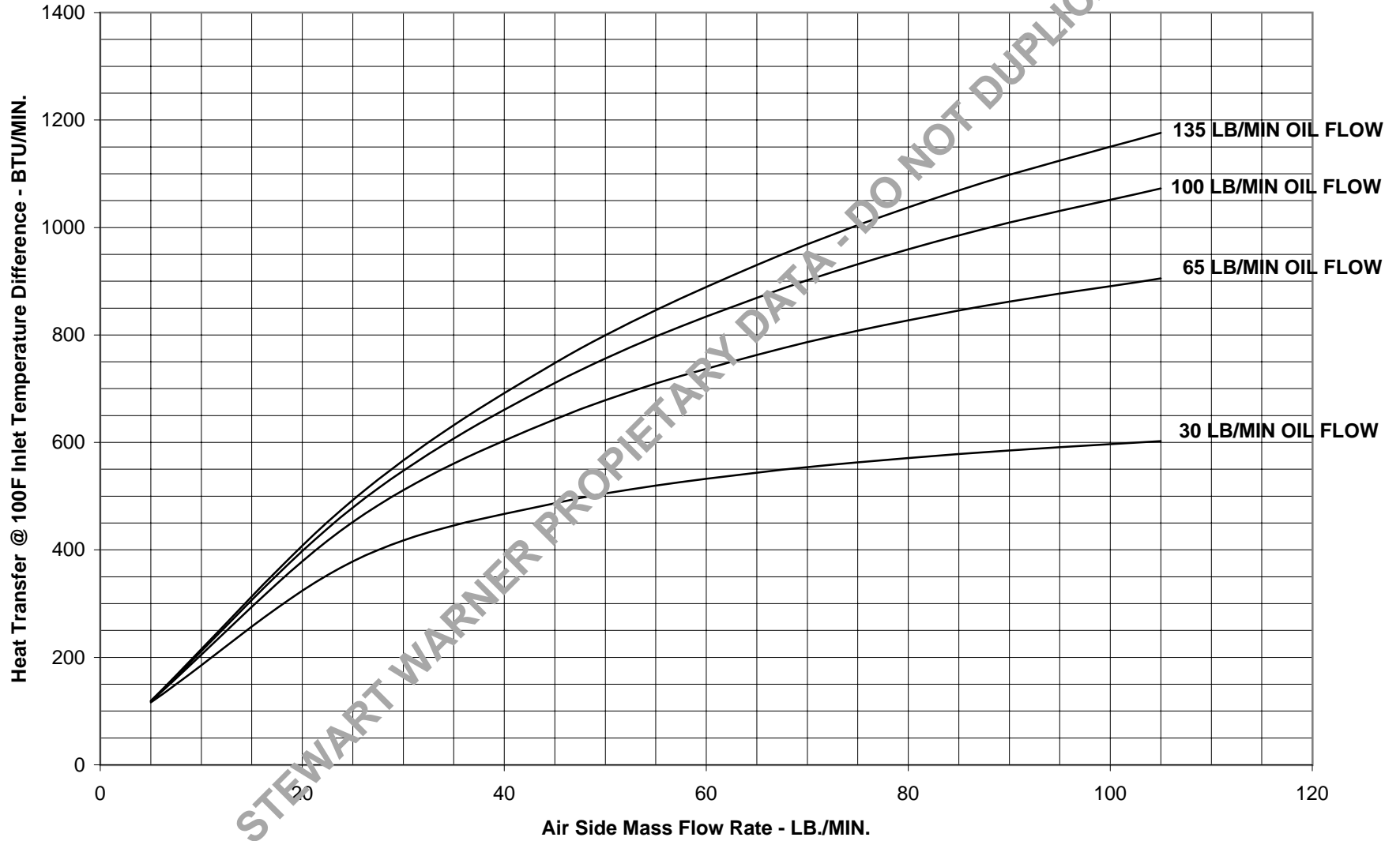

Stewart Warner 10886A Air Side Pressure Drop

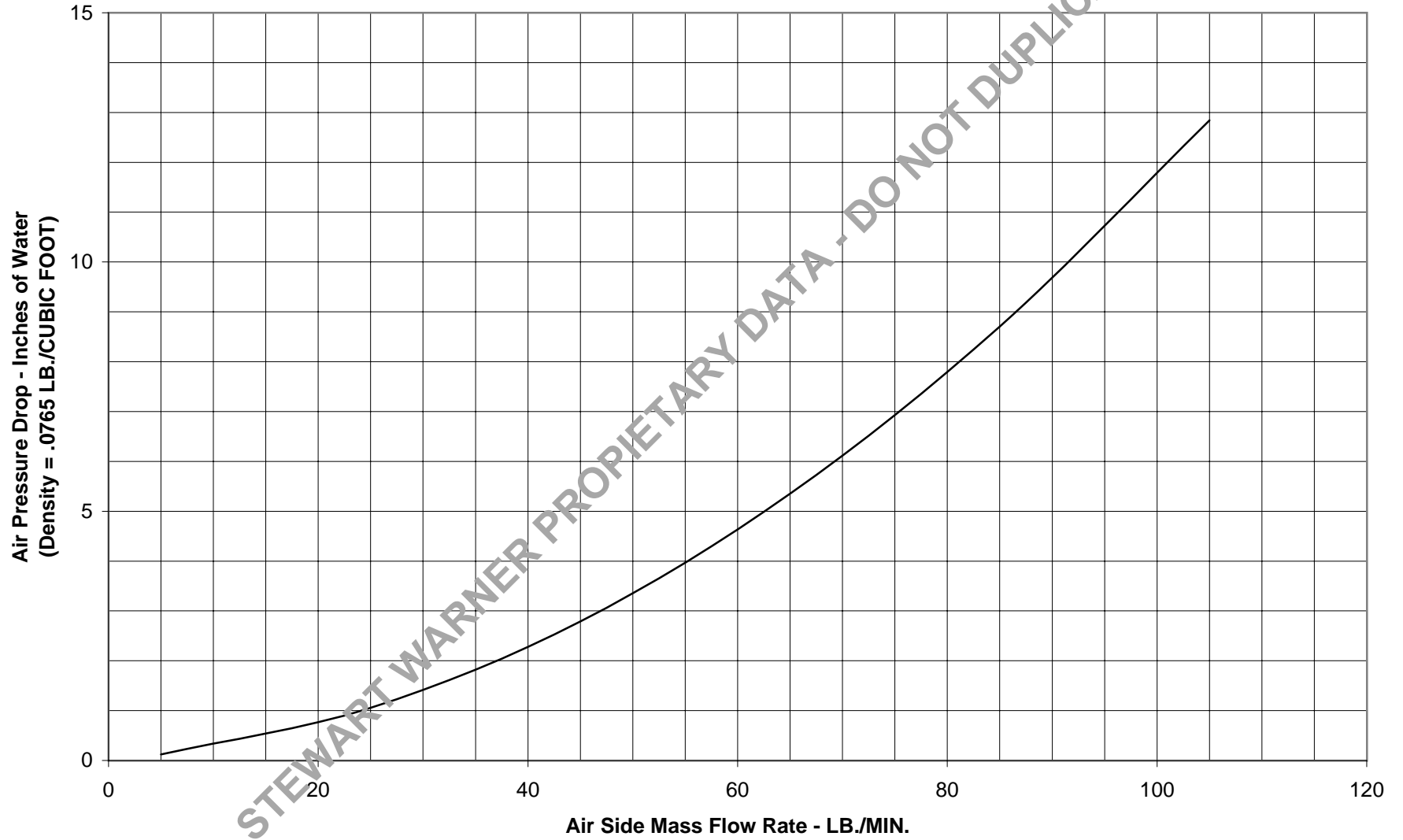

Stewart Warner 10886A Oil Side Pressure Drop

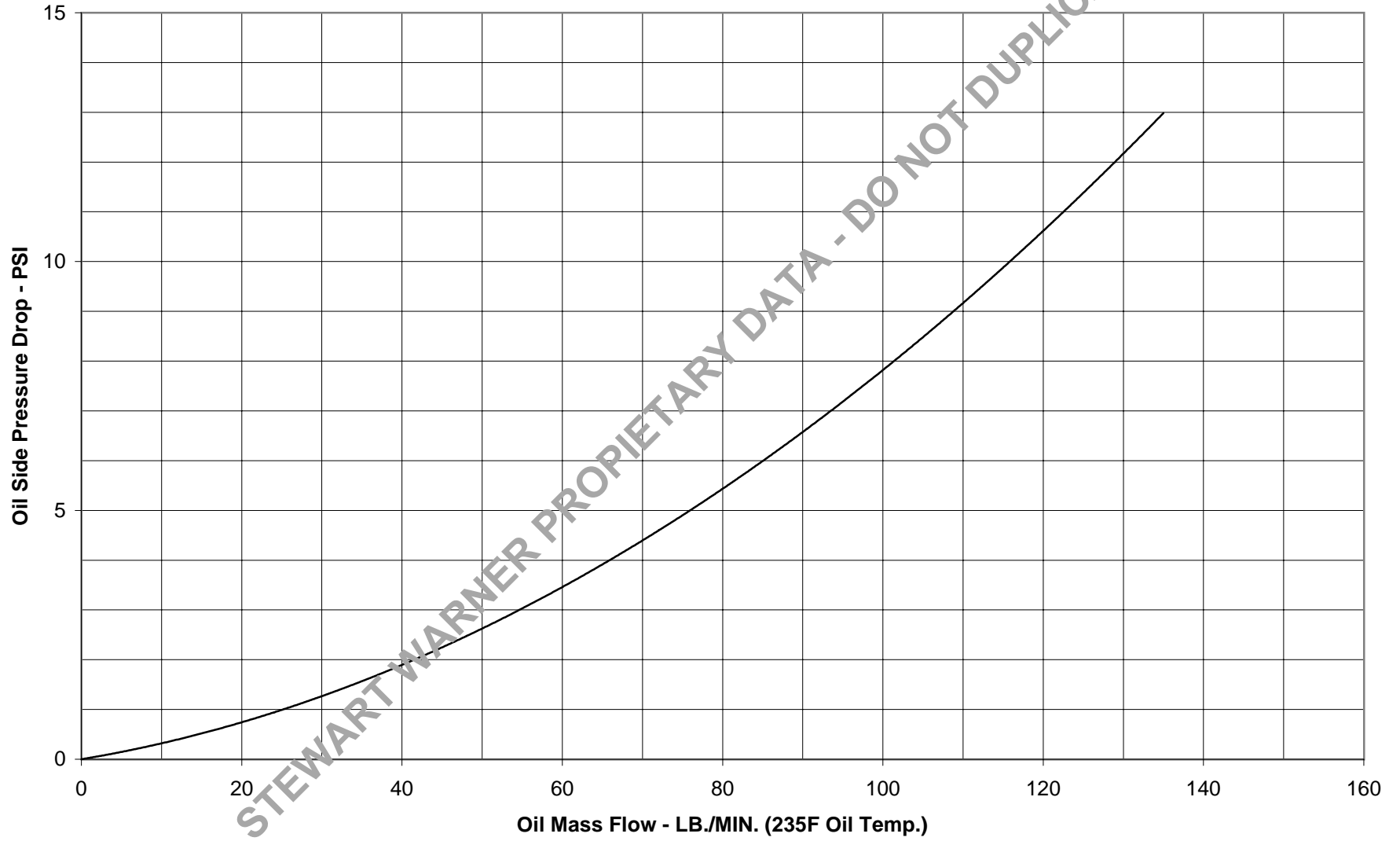

STEWART WARNER PROPRIETARY DATA - DO NOT DUPLICATE